

# Hydraulic Hybrid Pumps T6H\*

Denison Vane Technology, variable and fixed displacement

aerospace  
climate control  
electromechanical  
filtration  
fluid & gas handling  
**hydraulics**  
pneumatics  
process control  
sealing & shielding



ENGINEERING YOUR SUCCESS.

**Contents**

<b>GENERAL</b>	Features .....	3
	Instructions .....	3
	Minimum & maximum speeds .....	4
	Pressure ratings .....	4
	Priming at starting .....	4
	Minimum allowable inlet pressure.....	5
	General characteristics.....	5
	Pump selection : Routine and example .....	6
	Intermittent pressure rating.....	6
	Formulas.....	7
	Description .....	8
	Application advantages .....	8
	Controls C, F & L & X .....	9
	Hydraulic fluids .....	10
	Shafts .....	11
<b>T6H20B - T6H20C</b>	Ordering code & Operating characteristics.....	12
<b>T6H20B - T6H20C</b>	Dimensions.....	13
<b>T6H20B</b>	Technical data.....	14
<b>T6H20C</b>	Technical data.....	15
<b>T6H29B - T6H29C</b>	Ordering code & Operating characteristics.....	16
<b>T6H29B - T6H29C</b>	Dimensions.....	17
<b>T6H29B</b>	Technical data.....	18
<b>T6H29C</b>	Technical data.....	19
<b>T6H29D</b>	Ordering code & Operating characteristics.....	20
<b>T6H29D</b>	Dimensions.....	21
<b>T6H29D</b>	Technical data.....	22
<b>T6H29DB</b>	Ordering code & Operating characteristics.....	23
<b>T6H29DB</b>	Dimensions.....	24
<b>T6H29DB</b>	Technical data.....	25
<b>T6H20B - T6H20C</b>	Porting diagrams .....	26
<b>T6H29B - T6H29C - T6H29D</b>	Porting diagrams .....	26
<b>T6H29DB</b>	Porting diagrams .....	27

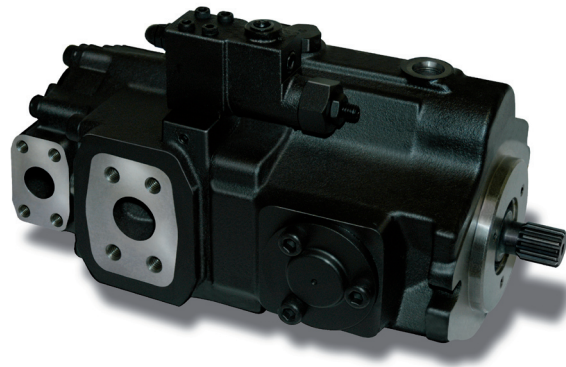

**DESCRIPTION**

The hybrid pump is a combination of fixed displacement vane pump B, C, D cartridges combined with a variable cartridge of PV20 or PV29 piston pump. The cartridges are driven by a common shaft without coupling in between they have a large common suction port and two or three independent outlet ports : One for the piston, one or two for the vane pump.

**FEATURES**

These pumps have very compact displacement and are under all actual pump sizes of the market.

**GREAT FLOW**

- T6H20B = 42,9 ml/rev variable + 5,8 to 50,0 ml/rev fixed
- T6H20C = 42,9 ml/rev variable + 10,8 to 100,0 ml/rev fixed
- T6H29B = 61,9 ml/rev variable + 5,8 to 50,0 ml/rev fixed
- T6H29C = 61,9 ml/rev variable + 10,8 to 100,0 ml/rev fixed
- T6H29D = 61,9 ml/rev variable + 47,6 to 158,0 ml/rev fixed
- T6H29DB = 61,9 ml/rev variable + 47,6 to 158,0 ml/rev fixed + 5,8 to 50,0 ml/rev fixed

**HIGH PRESSURE**

Continuous pressure ratings for variable displacement units are 240 bar for T6H20B/C and 210 bar for T6H29B/C/D/DB.

This combined unit offers the advantage of low noise PV and vane pump which together increase safety and better acceptance of working conditions.

System saving because high pressure allows the use of smaller components... you can down size and gain real savings.

**FLEXIBILITY**

Both units fixed flow and variable flow having separated outlets allow simultaneous machine cycles eg : Mobile machine steering fonction working at the same time as the hydraulic cylinders boom functions.

- One Common suction port.
- P2 rear port 4 or 8 positions - P3 rear port 8 positions.
- Optional internal drain for variable piston pump.
- Compensator venting valve integrated.

Control options on variable displacement (piston pump).

- Compensator "C"
- Ventable pressure compensator "F"
- Load sensing compensator "L"
- Compensator with electric vent valve (only ext. drain) "X" (only T6H20B and T6H20C as standard)

Vane pump cartridge allows great flexibility with many different displacements with easy conversion or renewal.

Wide range of acceptable fluids from 1600 to 10 cSt can operate with mineral oil, biodegradable oil, and fire resistant fluids.

**GENERAL APPLICATIONS  
INSTRUCTIONS**

1. Check speed range, pressure, temperature, fluid quality, viscosity and pump rotation.
2. T6H pump case pressure should not exceed 0,7 bar (see datas).
3. Check inlet conditions of the pump, if it can accept application requirement.
4. Type of shaft : if it would support operating torque.
5. Coupling must be chosen to minimize pump shaft load (weight, misalignment).
6. Filtration : must be adequate for lowest contamination level.
7. Environment of pump : to avoid noise reflection, pollution and shocks.
8. Although the T6H pumps have fast off stroke compensator reponse, system relief valves are recommended for safety considerations.
9. When constantly under pressure with no flow requirements, it is safer to flush the piston pump. Three drains holes are there for this purpose.

**Speed and Pressure Ratings**

Port	Size	Series	Theoretical Displacement Vi	Minimum Speed	Maximum Speed		Maximum Pressure					
					HF-0, HF-1 HF-2	HF-3, HF-4 HF-5	HF-0, HF-2		HF-1, HF-4, HF-5		HF-3	
					RPM	RPM	Int. <sup>3)</sup>	Cont.	Int. <sup>3)</sup>	Cont.	Int. <sup>3)</sup>	Cont.
P1	T6H20		42,9	600	2600 <sup>1)</sup>	1800	280	240	175 <sup>2)</sup>	140 <sup>2)</sup>	175	140
	T6H29		61,9	600	2400 <sup>1)</sup>	1800	250	210	175 <sup>2)</sup>	140 <sup>2)</sup>	175	140
P2 or P3	B	B02	5,8	600	2600	1800	300	275	240	210	175	140
		B03	9,8									
		B04	12,8									
		B05	15,9									
		B06	19,8									
		B07	22,5									
		B08	24,9									
		B10	31,8									
		B12	41,0									
P2	C	*03	10,8	600 (400) (mobile)	2600	1800	275	240	210	175	175	140
		*05	17,2									
		*06	21,3									
		*08	26,4									
		*10	34,1									
		*12	37,1									
		*14	46,0									
		*17	58,3									
		*20	63,8									
		*22	70,3									
		*25	79,3									
	*28	88,8										
	*31	100,0										
	D	014	47,6	600	2400	1800	240	210	210	175	175	140
		017	58,2									
		020	66,0									
		024	79,5									
		028	89,7									
		031	98,3									
035		111,0										
038		120,3										
042		136,0										
045	145,7											
050	158,0											

\* = 0 : Industrial application = B : Industrial bi-rotational = M : Mobile application

1) See page 11 for max. pressure f(n).

2) Max. pressure HF-1 same as HF-0 and HF-2.

3) See page 6 for conditions.

HF-0, HF-2 = Antiwear Petroleum Base

HF-1 = Non Antiwear Petroleum Base

HF-5 = Synthetic Fluids

HF-3 = Water in oil Emulsions

HF-4 = Water Glycols

For further information or if the performance characteristics outlined above do not meet your own particular requirements, please consult your local Parker representative.

**PRIMING AT STARTING**

At first start operation of the pump, run it at the lowest speed and at the lowest pressure to obtain priming. When a pressure relief valve is used at the outlet it should be backed off to minimize return pressure. An air bleed off should be provided in the circuit to facilitate the priming. Never operate pump shaft at top speed and pressure without checking for completion of pump priming, and that the fluid is not aerated.

**Always fill the housing of the T6H with oil of circuit prior to start up.**





Cartridge		Speed RPM							Series				
Size	Series	1200	1500	1800	2100	2200	2400	2600					
T6H20		0,80	0,80	0,80	0,80	0,80	0,85	0,90	T6H20				
T6H29		0,80	0,80	0,80	0,86	1,00	1,04		T6H29				
B	B02	0,80	0,80	0,80	0,80	0,80	0,80	0,80	B02				
	B03								B03				
	B04								B04				
	B05								B05				
	B06								B06				
	B07								B07				
	B08								B08				
	B10								B10				
	B12								B12				
	B15								0,84	B15			
C	*03	0,80	0,80	0,80	0,80	0,80	0,80	0,80	*03				
	*05								*05				
	*06								*06				
	*08								*08				
	*10								*10				
	*12								0,85	0,92	*12		
	*14								0,85	0,95	*14		
	*17								0,85	0,90	*17		
	*20								0,85	0,90	*20		
	*22								0,85	0,90	0,98	*22	
	*25								0,90	0,95	0,95	*25	
	*28								0,90	0,98	0,98	*28	
*31	0,85	0,90	1,00	*31									
D	014	0,80	0,80	0,80	0,80	0,88	0,95	1,00	014				
	017								017				
	020								020				
	024								0,82	1,10	025		
	028								0,85	0,92	1,00	1,18	028
	031								0,90	0,95	1,00	1,23	031
	035								0,92	0,98	1,02	1,29	035
	038								0,95	1,00	1,05		038
	042								1,02	1,08			042
	045								0,85	0,98	1,05		045
	050								1,02	1,09			050
	T6H20								Max. case P	0,69	0,69	0,69	0,34
T6H29	(bar relative)	0,69	0,69	0,69	0,34	0,34	0,34		T6H29				

**Vane cartridge :** Inlet pressure is measured at inlet flange with petroleum base fluids at viscosity between 10 and 65 cSt. The difference between inlet pressure (at the pump flange) and atmospheric pressure must not exceed 0,2 bar absolute to prevent aeration.

**Piston cartridge :** Rapid compensation at high speeds can cause severe case spikes. If the pump feeds into a blocked center valve that close quickly, use both case drain ports and direct short case drain lines and a relief valve.

Multiply absolute pressure by 1,25 for HF-3, HF-4 fluids.

by 1,35 for HF-5 fluid.

by 1,10 for ester or rapeseed base.

**GENERAL CHARACTERISTICS**

	Mounting standard	Weight without connector and bracket - kg	Moment of inertia kg m <sup>2</sup> x 10 <sup>-4</sup>	SAE 4 bolts J518c ISO/DIS 6162-1 or 6162-2			
				Suction	Pressure P1	Pressure P2	Pressure P3
T6H20B	SAE J744c	37,0	42,9	2.1/2"	1.1/4"	3/4" or 1"	
T6H20C	ISO-3019-1 - SAE B 101-2	37,0	46,7				
T6H29B	SAE J744c ISO-3019-1 - SAE C 127-2	49,0	64,2				
T6H29C		49,0	68,0				
T6H29D		60,0	80,7				
T6H29DB		72,0	83,9	3"	1.1/4"	3/4" or 1"	



**CALCULATION**

<i>To resolve</i>		Performances required - (P1 - P2)
Volumetric displacement	$V_i$ [ml/rev.]	Requested flow $Q$ [l/min] 60
Available flow	$Q$ [l/min]	Speed $n$ [R.P.M.] 1500
Input Power	$P$ [Kw]	Pressure $p$ [bar] 150

**ROUTINE AND EXAMPLE**

<i>Routine :</i>	<i>Example :</i>
1. First calculation $V_i = \frac{1000 Q}{n}$	$V_i = \frac{1000 \times 60}{1500} = 40$ ml/rev.
2. Choice $V_i$ of each section of pump immediately greater <i>P1 = Piston cartridge T6H20</i> <i>P2 = Vane cartridge (see tabulation) then the pump will be</i>	Stage P1 : T6H20 $V_i = 42,9$ ml/rev. Stage P2 : Size C 014 $V_i = 46,0$ ml/rev. T6H20C - 014
3. Theoretical flow of this pump  $Q_{theo.} = \frac{V_i \times n}{1000}$	Stage P1 : $Q_{theo.} = \frac{42,9 \times 1500}{1000} = 64,35$ l/min Stage P2 : $Q_{theo.} = \frac{46 \times 1500}{1000} = 69$ l/min
4. Available flow <i>P1 - Consult the curve "Full flow"</i>  <i>P2 - Find <math>q_s</math> leakage function of pressure <math>q_s = f(p)</math> on curve at 10 or 24 cSt</i> $Q = Q_{theo.} - q_s$	Stage P1 : 1500 R.P.M. at 150 bar = 62 l/min T6H20C (page 15) : Stage P2 : $q_s = 5$ l/min at 150 bar, 24 cSt Stage P2 : $Q = 69 - 5 = 64$ l/min
5. Theoretical input power <i>P1 : Piston section - Consult curve</i>  $P2 : \frac{Q_{theo.} \times p}{600}$	T6H20C (page 15) Stage P1 : Curve "Inlet horsepower" 1500 R.P.M. at 150 bar = 18 kW Stage P2 : $\frac{69 \times 150}{600} = 17,3$ kW
6. Find $P_s$ hydrodynamic power loss on curve	T6H20C (page 15) : $P_s$ at 1500 R.P.M., 150 bar = 1.5 kW
7. Total input power $P = P (P1) + P (P2) + P_s$	$P = 18 + 17,3 + 1,5 = 36,8$ kW
8. Results	T6H20C - 014 P1 $V_i = 42,9$ ml/rev $Q = 62,0$ l/min Input horsepower P2 $V_i = 46,0$ ml/rev $Q = 64,0$ l/min $p = 36,8$ kW

**INTERMITTENT PRESSURE RATING**

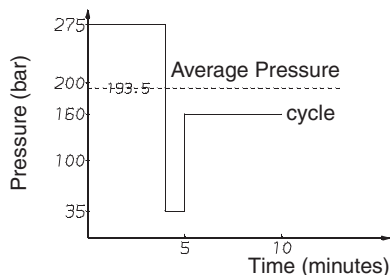

Piston cartridge section (P1) may be operated at an intermittent pressure but 10% of operation time only, not exceeding 6 successive seconds.  
 Vane cartridge section units may be operated intermittently at pressures higher than the recommended continuous rating when the time weighted average of pressure is less than or equal to the continuous duty pressure rating.  
 This intermittent pressure rating calculation is only valid if other parameters; speed, fluid, viscosity and contamination level are respected.  
 For total cycle time higher than 15 minutes please consult your Parker representative.

Example : T6H20C - 014  
 P2 - Duty cycle 4 min. at 275 bar  
 1 min. at 35 bar  
 5 min. at 160 bar  

$$\frac{(4 \times 275) + (1 \times 35) + (5 \times 160)}{10} = 193,5 \text{ bar}$$

193,5 bar is lower than 240 bar allowed as continuous pressure for T6H20C - 014 with HF-0 fluid.

**FLUID POWER FORMULAS**

<i>Pump input torque</i>	<i>N.m</i>	$\frac{\text{pressure (bar)} \times \text{displacement (ml/rev)}}{20 \pi \times \text{mech. eff.}}$
<i>Pump input power</i>	<i>kW</i>	$\frac{\text{speed (rpm)} \times \text{displacement (ml/rev)} \times \text{pressure (bar)}}{600000 \times \text{overall eff.}}$
<i>Pump output flow</i>	<i>Lpm</i>	$\frac{\text{speed (rpm)} \times \text{displacement (ml/rev)} \times \text{volumetric eff.}}{1000}$
<i>Fluid motor speed</i>	<i>rpm</i>	$\frac{1000 \times \text{flow rate (Lpm)} \times \text{volumetric eff.}}{\text{displacement (ml/rev.)}}$
<i>Fluid motor torque</i>	<i>N.m</i>	$\frac{\text{pressure (bar)} \times \text{displacement (ml/rev)} \times \text{mech. eff.}}{20 \pi}$
<i>Fluid motor power</i>	<i>kW</i>	$\frac{\text{speed (rpm)} \times \text{displacement (ml/rev)} \times \text{pressure (bar)} \times \text{overall eff.}}{600000}$

## Description

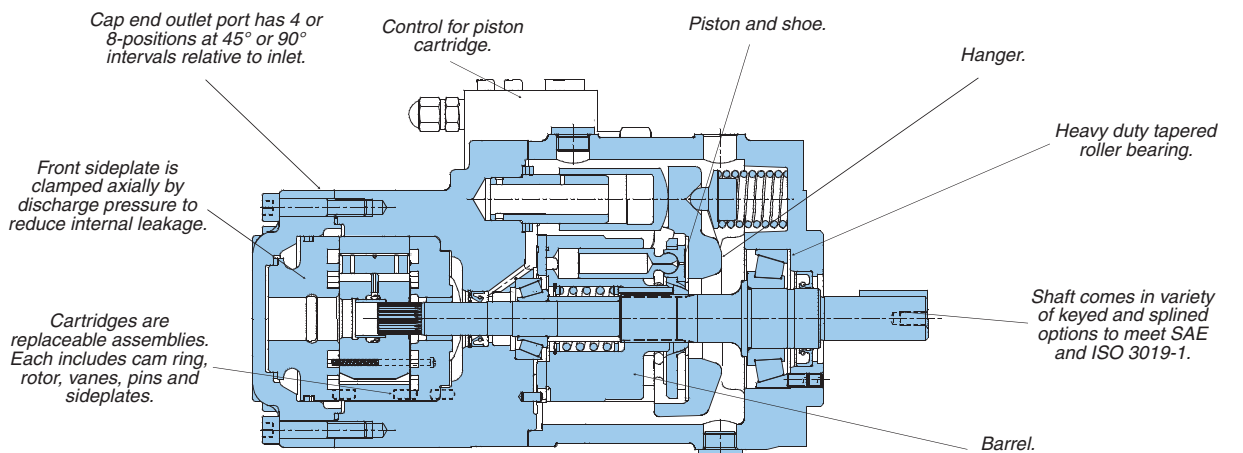

### MOBILE VERSION

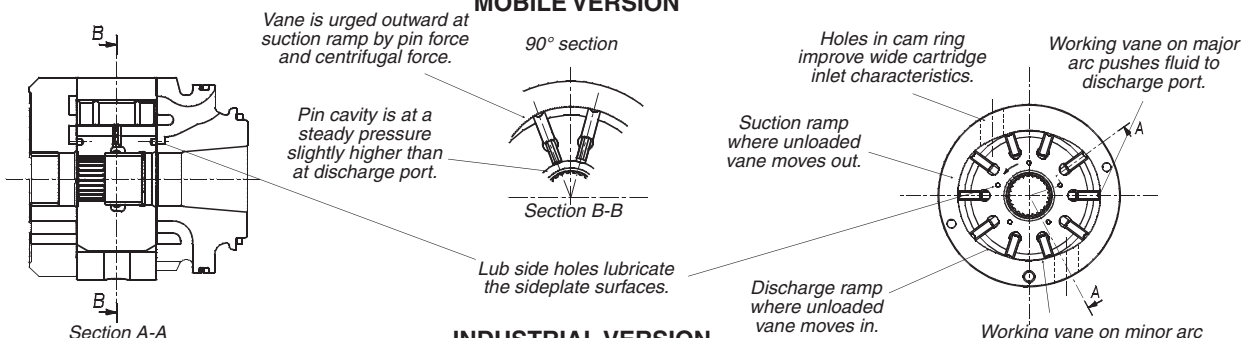

### INDUSTRIAL VERSION

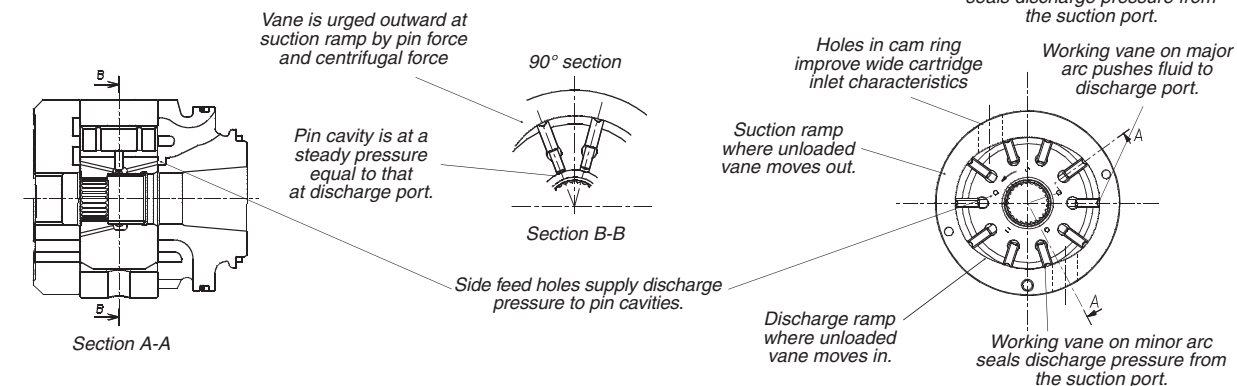

## APPLICATION ADVANTAGES

- The high pressure capability to 240 bar, in the small envelope, reduces installation costs and provides extended life at reduced pressure.
- The high volumetric efficiency, typically 94%, reduces heat generation, and allows speeds down to 600 RPM (400 RPM for mobile) at full pressure.
- The high mechanical efficiency, typically 94%, reduces energy consumption.
- The wide speed range from 600 RPM to 2600 RPM (400 RPM to 2600 RPM for mobile), combined with large size cartridge displacements, will optimize operation for the lowest noise level in the smallest envelope.
- The low speed 600 RPM (400 RPM for mobile), low pressure, high viscosity 860 cSt (1600 cSt for mobile) allow application in cold environments with a minimum energy consumption and without of seizure risk.
- The low ripple pressure  $\pm 2$  bar reduces piping noise and increases life time of the other components in the circuit.
- The high resistance to particle contamination because of the double lip vane increases pump life.
- The large variety of options (cam displacement, shaft, porting, piston section controls) allows customized installation.

**Controls**

**C - COMPENSATOR**

The "C" and "F" pressure compensator control allows the pump to deliver full volume from the outlet port until the pressure rise to the value set by the control. The control then reduces the pump volume to that required by the system mobile maintaining the preset pressure at the outlet port.

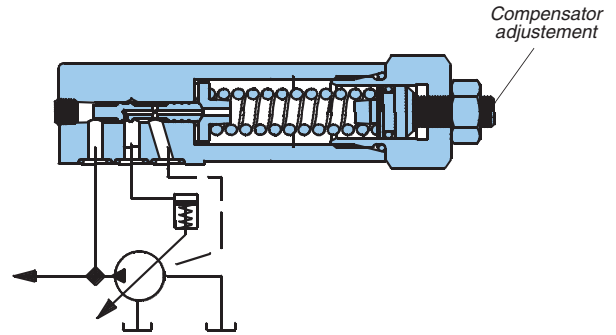

**F - VENTABLE COMPENSATOR**

The "F" compensator is used in applications requiring remote control pressure. The remote relief is connected to the vent port. The pressure may be controlled at any level below the compensator pressure setting. The vent port may also be used to remotely vent-off the compensator for starting.

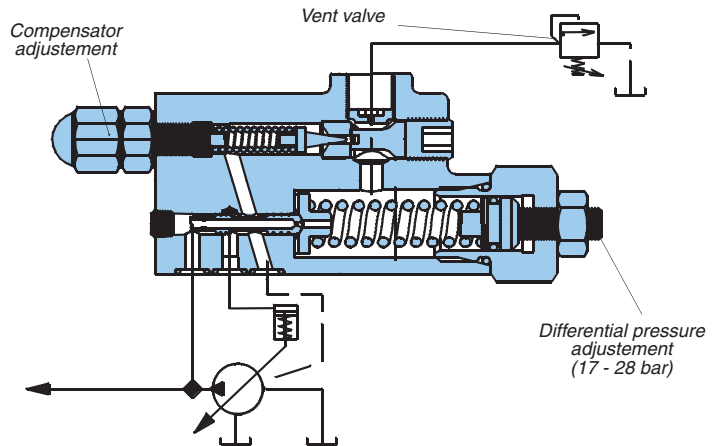

**L - LOAD SENSING COMPENSATOR**

The "L" compensator is used for load sensing circuits and is a true load ensor. This is the "F" compensator with a pin in the compensator spool (see enlarged view). The pin prevents pilot flow from entering the circuit which will eliminate creeping of the load. The "L" compensator will let the pump deliver a constant flow rate to the circuit by providing an adjustable  $\Delta P$  across the customers orifice or valve. The pump will operate at 17 - 28 bar above "Load Pressure".

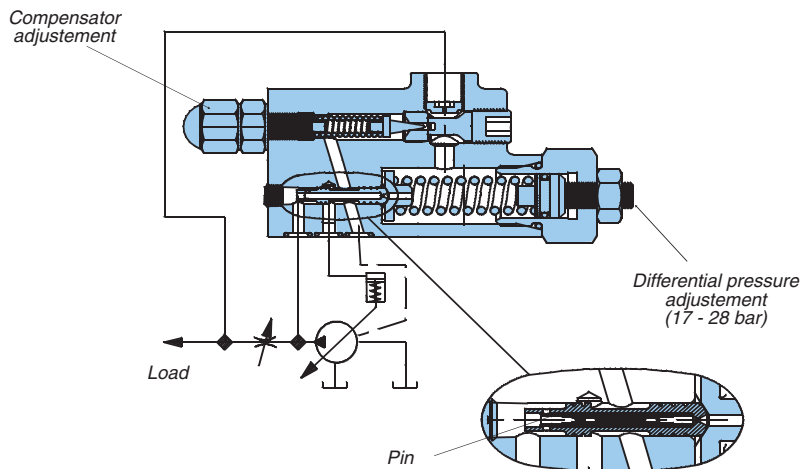

**X - VENTED COMPENSATOR BY ELECTRIC VALVE**

The "X" compensator is used in application requiring vent off on compensator at starting or at other time of the cycle. The piston cartridge reduce the volume for maintaining the pressure at the differential pressure setting.

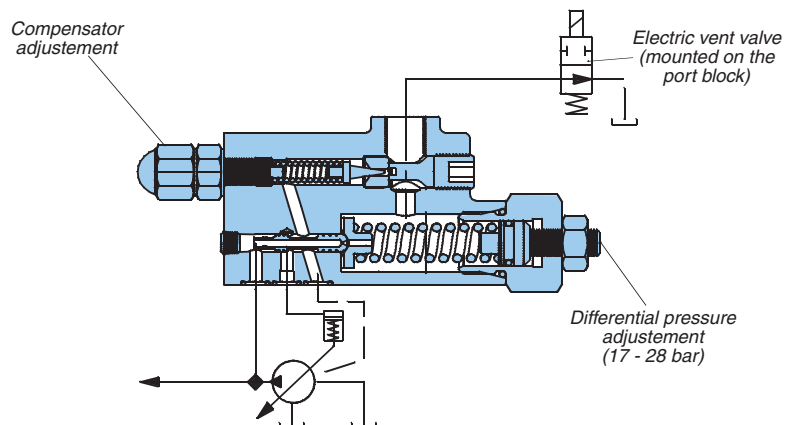

**FLUIDS**

Petroleum based antiwear R & O fluids.

**RECOMMENDED FLUIDS**

These fluids are the recommended fluids for T6 series pumps. Maximum catalogue ratings and performance data are based on operation with these fluids. These fluids are covered by Denison HF-0 and HF-2 specification.

**ACCEPTABLE ALTERNATE FLUIDS**

The use of fluids other than petroleum based antiwear R & O fluids, requires that the maximum ratings of the pumps will be reduced. In some cases the minimum replenishment pressures must be increased. Consult specific sections for more details.

**VISCOSITY**

Max (cold start, low speed & pressure)	_____	860 mm <sup>2</sup> /s (cSt)
Max (cold start, low speed & pressure) (for mobile)	_____	1600 mm <sup>2</sup> /s (cSt)
Max (full speed & pressure)	_____	108 mm <sup>2</sup> /s (cSt)
Optimum (max. life)	_____	30 mm <sup>2</sup> /s (cSt)
Min (full speed & pressure for HF-1, HF-3, HF-4 & HF-5 fluids)	_____	18 mm <sup>2</sup> /s (cSt)
Min (full speed & pressure for HF-0 & HF-2 fluids)	_____	13 mm <sup>2</sup> /s (cSt)

**VISCOSITY INDEX**

90° min. higher values extend range of operating temperatures.

Maximum fluid temperature (θ) °C

HF-0, HF-1, HF-2	+ 100° C
HF-3, HF-4	+ 50° C
HF-5	+ 70° C
Biodegradable fluids (esters & rapeseed base)	+ 65° C

Minimum fluid temperature (θ) °C

HF-0, HF-1, HF-2, HF-5	- 18° C
HF-3, HF-4	+ 10° C
Biodegradable fluids (esters & rapeseed base)	- 20° C

**FLUID CLEANLINESS**

The fluid must be cleaned before and during operation to maintain contamination level of NAS 1638 class 8 (or ISO 19/17/14) or better. Filters with 25 micron (or better, β<sub>10</sub> ≥ 100) nominal ratings may be adequate but do not guarantee the required cleanliness levels. Suction strainers must be of adequate size to provide minimum inlet pressure specified. 100 mesh (149 micron) is the finest mesh recommended. Use oversize strainers or omit them altogether on applications which require cold starts or use fire resistant fluids.

**OPERATING TEMPERATURES AND VISCOSITIES**

Operating temperatures are a function of fluid viscosities, fluid type, and the pump. Fluid viscosity should be selected to provide optimum viscosity at normal operating temperatures. For cold starts the pumps should be operated at low speed and pressure until fluid warms up to an acceptable viscosity for full power operation.

**WATER CONTAMINATION IN THE FLUID**

Maximum acceptable content of water.

- 0.10% for mineral base fluids.
  - 0.05% for synthetic fluids, crankcase oils, biodegradable fluids.
- If amount of water is higher then it should be drained off the circuit.



**SHAFTS  
COUPLINGS AND FEMALE SPLINES  
SPLINES**

- The shafts will accept a maximum misalignment of 0.06 TIR when the pump is foot mounted and 0.03 mm when flange mounted. The angular alignment of two spline axes must be less than 0.1° (0.002 mm/mm).
- The coupling spline must be lubricated with a lithium molydisulfide grease or a similar lubricant.
- The coupling must be hardened to a hardness between 27 and 45 R.C.
- The female spline must be made to conform to the Class 1 fit as described in SAE-J498b (1971). This is described as a Flat Root Side Fit.

**KEYED SHAFTS**

We supply the T6H series keyed shaft pumps with high strength heat-treated keys. Therefore, when installing or replacing these pumps, the heat-treated keys must be used in order to insure maximum life in the application. If the key is replaced it must be a heat-treated key between 27 and 34 R.C. hardness. The corners of the keys must be chamfered from 0.76 to 1.02 at 45° to clear radius in the key way.

**NOTE**

Alignment of keyed shafts must be within tolerances given for splined shafts.

**SHAFT LOADS**

These products are designed primarily for coaxial drives which do not impose axial or side loading on the shaft. Consult the typical curve below for the theoretical life. For specific applications which may include vibration and shock during operation of the machine or external load on the drive shaft. Please consult your local Parker representative

**SHAFT BEARING LIFE (TYPICAL)  
WITHOUT EXTERNAL LOAD**

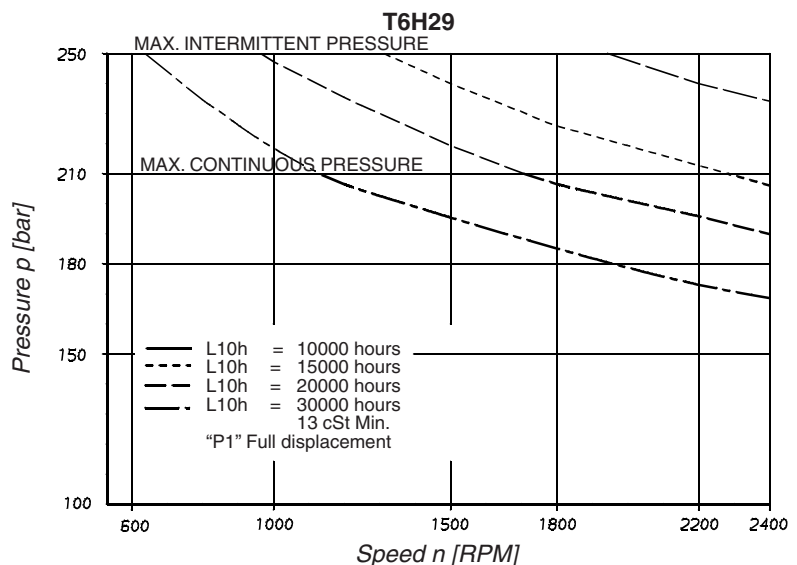
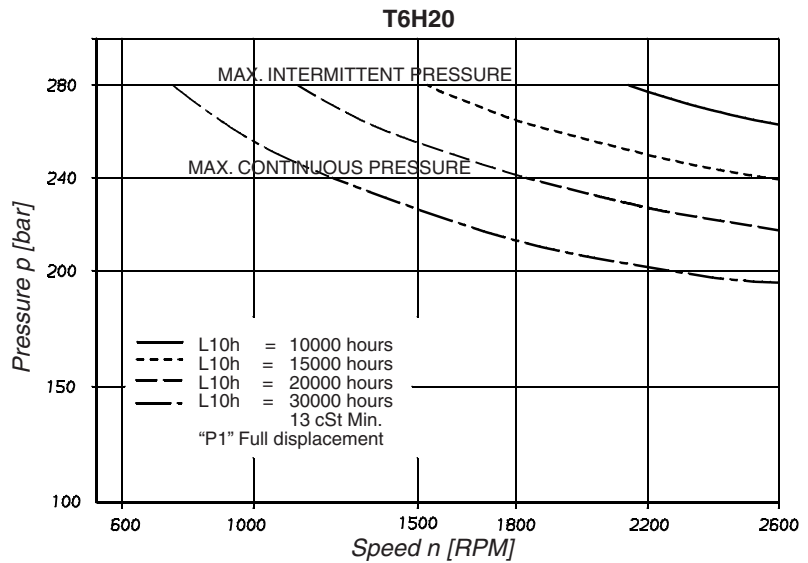

Model No. T6H20B - B08 - 1 L 1 B - 2 F 0 M 0 - 00 - ....  
T6H20C - \*12 - 1 L 1 C - 2 F 0 M 0 - 00 - ....

**Series and capacity P1**  
(rotating group)  
42,9 ml/rev.

**Cam ring P2**  
(Delivery at 0 bar & 1500 r.p.m.)

T6H20B	T6H20C
B02 = 8,7 l/min	*03 = 16,2 l/min
B03 = 14,7 l/min	*05 = 25,8 l/min
B04 = 19,2 l/min	*06 = 31,9 l/min
B05 = 23,9 l/min	*08 = 39,6 l/min
B06 = 29,7 l/min	*10 = 51,1 l/min
B07 = 33,7 l/min	*12 = 55,6 l/min
B08 = 37,4 l/min	*14 = 69,0 l/min
B10 = 47,7 l/min	*17 = 87,4 l/min
B12 = 61,5 l/min	*20 = 95,7 l/min
B15 = 75,0 l/min	*22 = 105,4 l/min
	*25 = 118,9 l/min
	*28 = 133,2 l/min
	*31 = 150,0 l/min

**Type of shaft**  
1 = keyed (SAE BB) 3 = splined (SAE C)  
4 = splined (SAE BB) 5 = keyed (SAE C)

**Direct. of rotation (view on shaft end)**  
R = clockwise  
L = counter-clockwise

**Seal class**  
1 = S1 BUNA N  
5 = S5 VITON®

**Design letter**  
B = T6H20B  
C = T6H20C

**Modification**

**Porting combination**  
Depend on the rotation - See page 26

**Variables port**

	Dia	Code
P2	1"	0
P2	3/4"	1

**Variables flanges connections**

4 bolts SAE flange (J518c)  
0 = UNC thread  
M = metric thread)

**Control accessories**

0 = Maxi flow  
9 = 90% maxi flow  
8 = 80% maxi flow  
7 = 70% maxi flow  
6 = 60% maxi flow  
5 = 50% maxi flow

**Control**

C = Compensator  
F = RC pilot operated compensator  
L = RC pilot operated compensator  
"load sensing"  
X\* = RC pilot operated compensator with  
vent valve 24 VDC  
\* Use with external drain only

**Connection (drain + vent.)**

0 = ext. drain + UNF thread  
2 = ext. drain + BSPP thread  
3 = int. drain + UNF thread  
4 = int. drain + BSPP thread

\* = 0 = Indust. uni-rotational / B = Indust. bi-rotational / M = Mobile bi-rotational

**OPERATING CHARACTERISTICS - TYPICAL [24 cSt]**

Pressure port	Series	Volumetric Displacement Vi	Flow Q [l/min], n = 1500 RPM				Input power P [kW], n = 1500 RPM			
			p = 0 bar	p = 140 bar		p = 300 bar	p = 7 bar	p = 140 bar	p = 300 bar	
P2 T6H20B	B02	5,8 ml/rev	8,7	7,0		5,1	0,5	2,6	5,1	
	B03	9,8 ml/rev	14,7	13,0		11,1	0,6	4,0	8,1	
	B04	12,8 ml/rev	19,2	17,5		15,6	0,6	5,0	10,4	
	B05	15,9 ml/rev	23,9	22,2		20,2	0,7	6,1	12,7	
	B06	19,8 ml/rev	29,7	28,0		26,1	0,7	7,5	15,6	
	B07	22,5 ml/rev	33,7	32,0		30,2	0,8	8,5	17,6	
	B08	24,9 ml/rev	37,4	35,7		33,7	0,8	9,3	19,5	
	B10	31,8 ml/rev	47,7	46,0		44,1	0,9	11,7	24,6	
	B12	41,0 ml/rev	61,5	59,8		57,9	1,2	14,9	31,5	
B15	50,0 ml/rev	75,0	73,3		71,6 <sup>1)</sup>	1,3	18,1	35,7 <sup>1)</sup>		
			p = 0 bar	p = 140 bar		p = 240 bar	p = 7 bar	p = 140 bar	p = 240 bar	
				Indust.	Mobile	Indust.	Mobile			
P2 T6H20C	*03	10,8 ml/rev	16,2	11,2	10,7	7,7	-	1,3	5,3	8,4
	*05	17,2 ml/rev	25,8	20,8	20,3	17,3	15,8	1,4	7,5	12,2
	*06	21,3 ml/rev	31,9	26,9	26,4	23,4	21,9	1,5	8,9	14,7
	*08	26,4 ml/rev	39,6	34,6	34,1	31,1	29,6	1,6	10,7	17,7
	*10	34,1 ml/rev	51,1	46,1	45,6	42,6	41,1	1,7	13,4	22,3
	*12	37,1 ml/rev	55,6	50,6	50,1	47,1	45,6	1,7	14,4	24,1
	*14	46,0 ml/rev	69,0	64,0	63,5	60,5	59,0	1,9	17,6	29,5
	*17	58,3 ml/rev	87,4	82,4	81,9	78,9	77,4	2,1	21,9	36,9
	*20	63,8 ml/rev	95,7	90,7	90,2	87,2	85,7	2,2	23,8	40,2
	*22	70,3 ml/rev	105,4	100,4	99,9	96,9	95,4	2,3	26,1	44,1
	*25	79,3 ml/rev	118,9	113,9	113,4	110,4	108,9	2,5	29,2	49,5
*28	88,8 ml/rev	133,2	128,2	127,7	125,8 <sup>2)</sup>	124,5 <sup>2)</sup>	2,8	32,7	48,5 <sup>2)</sup>	
*31	100,0 ml/rev	150,0	145,0	144,5	142,6 <sup>2)</sup>	141,3 <sup>2)</sup>	2,8	36,5	54,4 <sup>2)</sup>	

<sup>1)</sup> B15 = 280 bar max. int.

<sup>2)</sup> 028 - 031 = 210 bar max. int.

- Not to use because internal leakage greater than 50% theoretical flow.

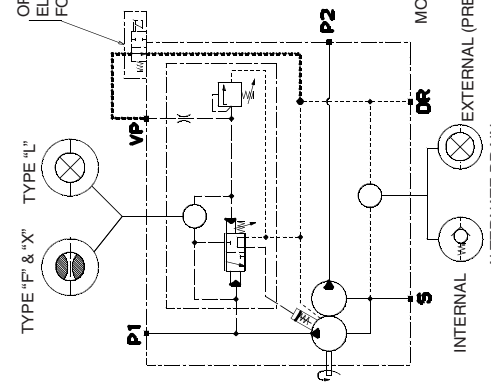
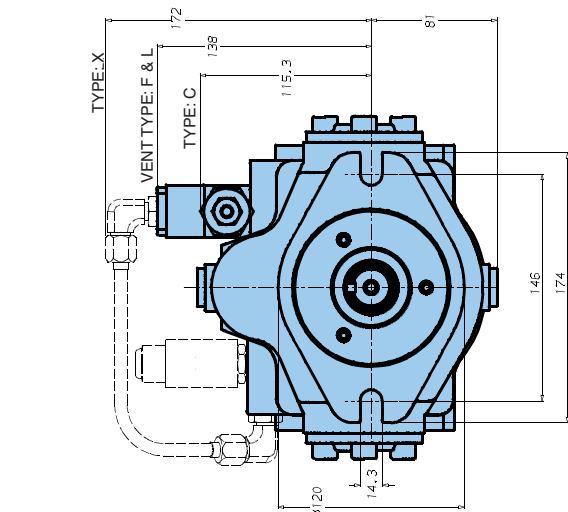
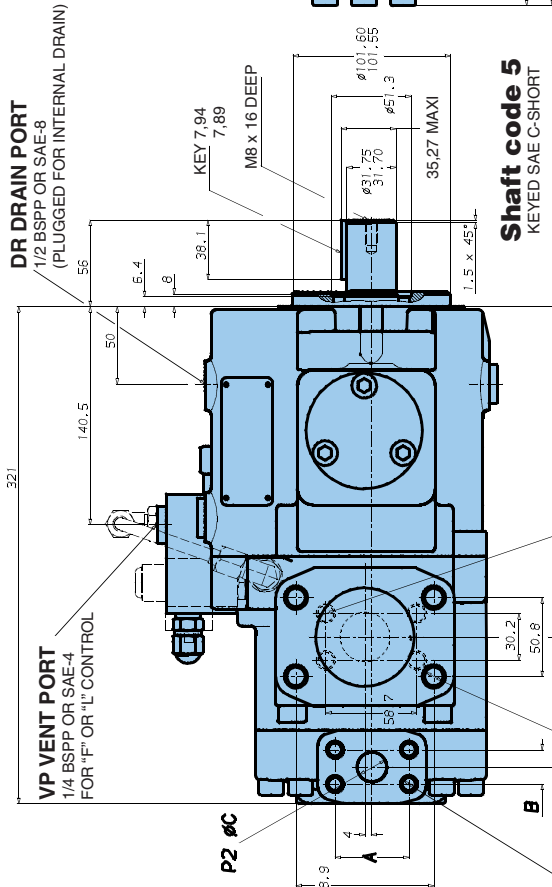
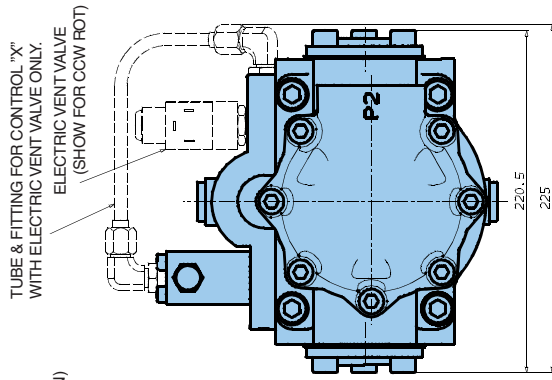

**HYDRAULIC CIRCUIT**  
(SHOWED FOR "F", "L" OR "X" CONTROL)

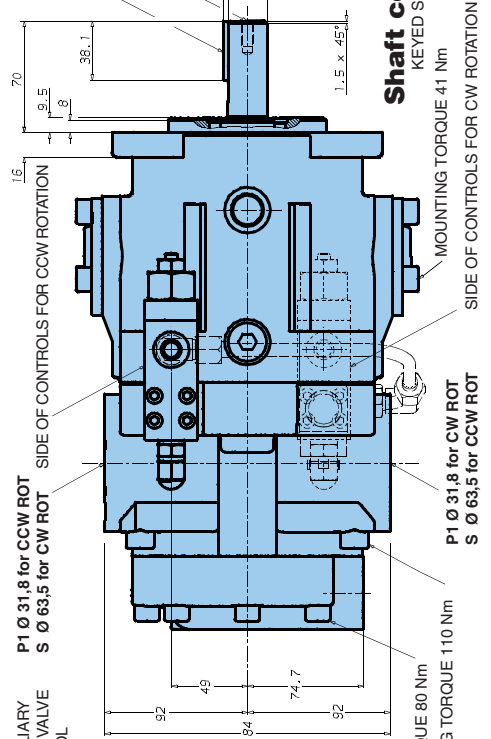

**Shaft torque limits [m/rev. x bar]**

Shaft	V1 x p max.
1	21420
4	32670

**Variable port**

Port	Code	A	B	Ø C
P2	0	52,4	26,2	25,4
P2	1	47,7	22,4	19,0

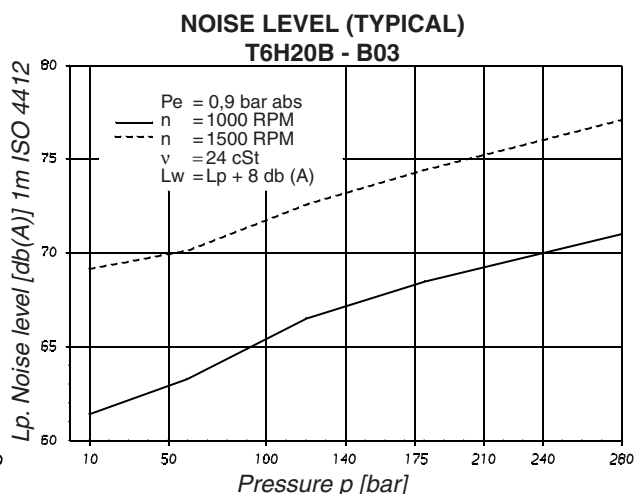
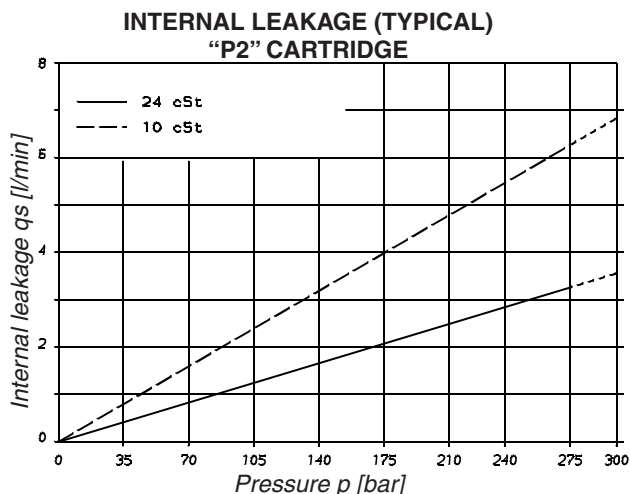

Do not operate pump more than 5 seconds at any speed or viscosity if internal leakage is higher than 50% of theoretical flow.

Noise level is given with each cartridge discharging at the pressure noted on the curve (P1 full flow).

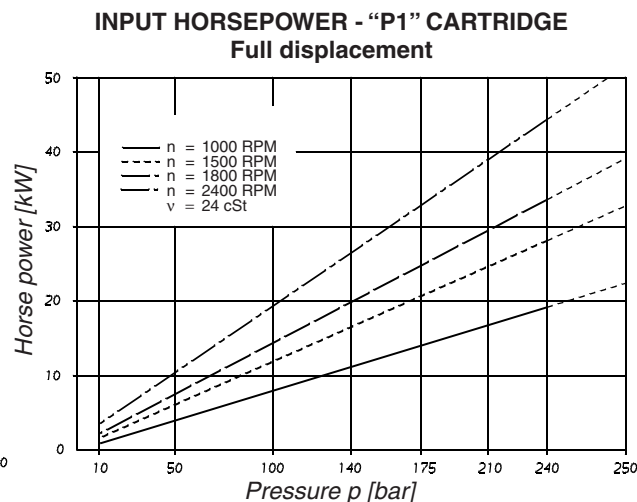
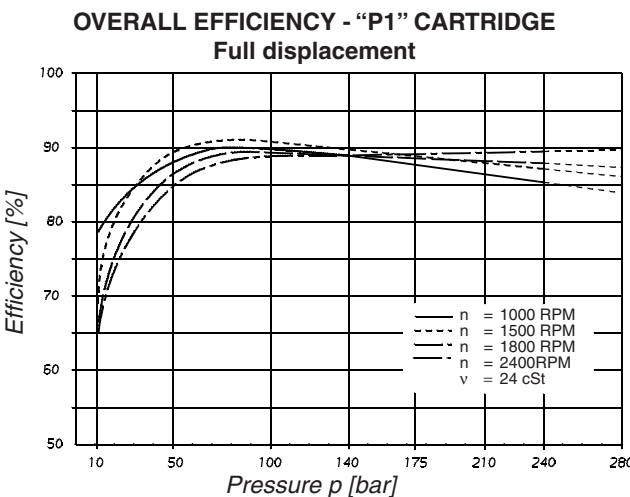
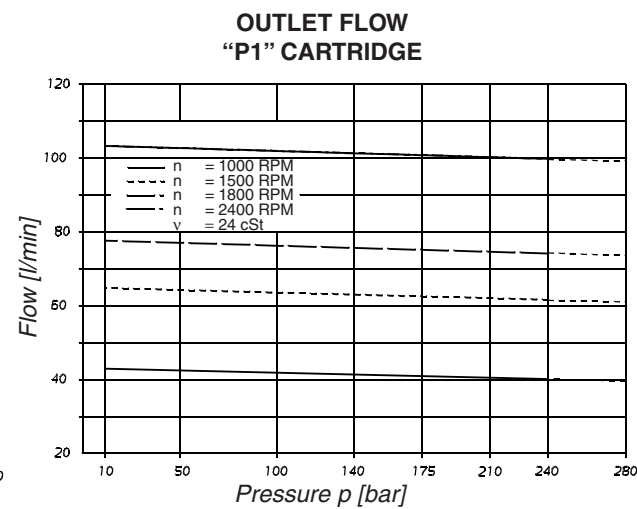
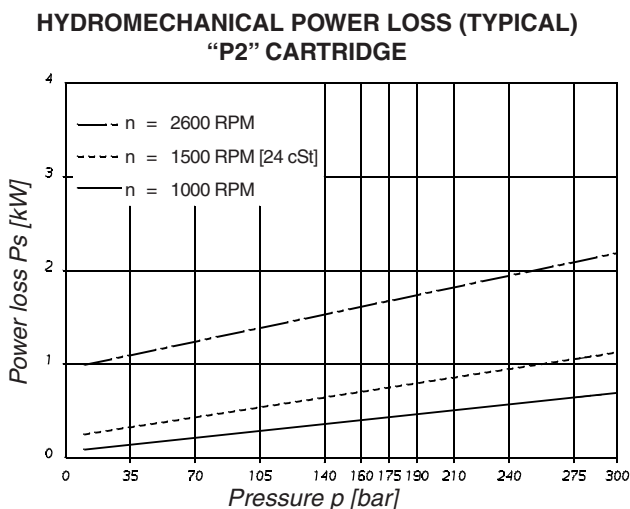

**INTERNAL LEAKAGE (TYPICAL)  
"P2" CARTRIDGE**

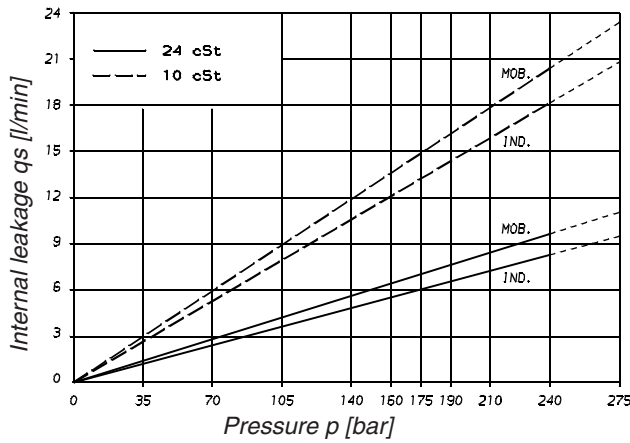

Do not operate pump more than 5 seconds at any speed or viscosity if internal leakage is higher than 50% of theoretical flow.

**NOISE LEVEL (TYPICAL)  
T6H20C - B22**

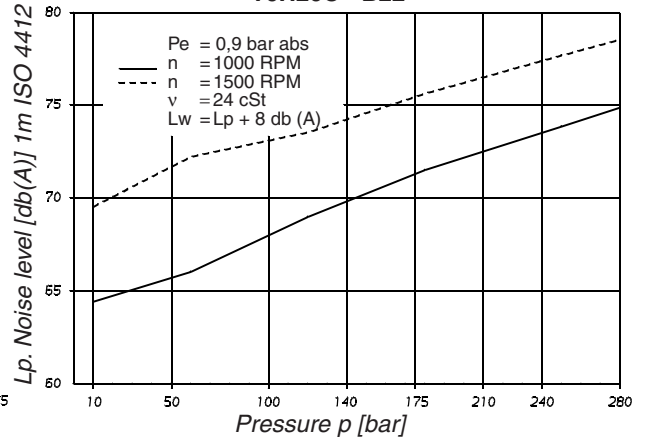

Noise level is given with each cartridge discharging at the pressure noted on the curve (P1 full flow).

**HYDROMECHANICAL POWER LOSS (TYPICAL)  
"P2" CARTRIDGE**

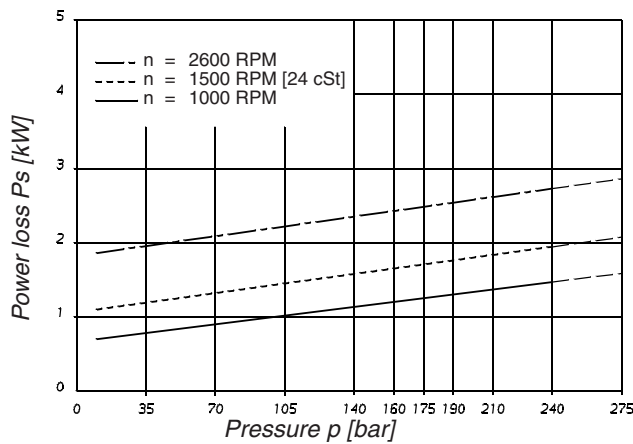

**OUTLET FLOW  
"P1" CARTRIDGE**

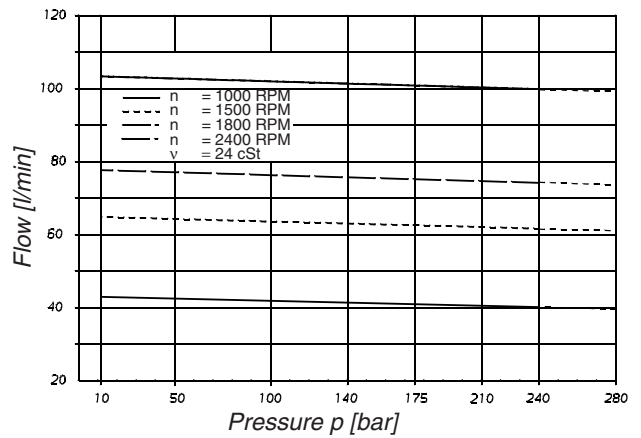

**OVERALL EFFICIENCY - "P1" CARTRIDGE  
Full displacement**

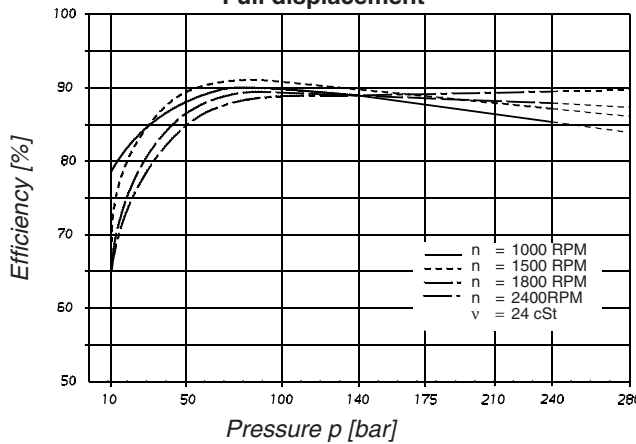

**INPUT HORSEPOWER - "P1" CARTRIDGE  
Full displacement**

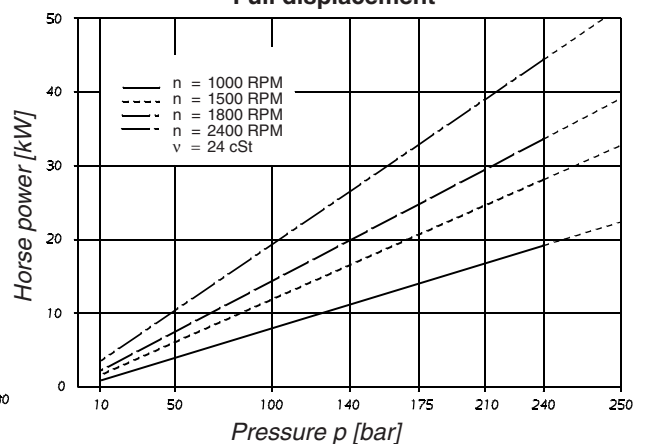

**Ordering Code and Characteristics**

**Model No.** T6H29B- B08 - 1 L 1 B - 2 F 0 M 0 - 00 - ....  
T6H29C- \*12 - 1 L 1 C - 2 F 0 M 0 - 00 - ....

**Series and capacity P1 (rotating group)**  
61,9 ml/rev.

**Cam ring P2 (Delivery at 0 bar & 1500 r.p.m.)**  
T6H29B T6H29C  
B02 = 8,7 l/min \*03 = 16,2 l/min  
B03 = 4,7 l/min \*05 = 25,8 l/min  
B04 = 19,2 l/min \*06 = 31,9 l/min  
B05 = 23,9 l/min \*08 = 39,6 l/min  
B06 = 29,7 l/min \*10 = 51,1 l/min  
B07 = 33,7 l/min \*12 = 55,6 l/min  
B08 = 37,4 l/min \*14 = 69,0 l/min  
B10 = 47,7 l/min \*17 = 87,4 l/min  
B12 = 61,5 l/min \*20 = 95,7 l/min  
B15 = 75,0 l/min \*22 = 105,4 l/min  
\*25 = 118,9 l/min  
\*28 = 133,2 l/min  
\*31 = 150,0 l/min

**Type of shaft**  
1 = keyed (SAE C)  
4 = splined (SAE C)

**Direct. of rotation (view on shaft end)**  
R = clockwise  
L = counter-clockwise

**Seal class**  
1 = S1 BUNA N  
5 = S5 VITON®

**Design letter**

**Modification**  
**Porting combination**  
Depend on the rotation - See page 26

**Variable port**

	Dia	Code
P2	1"	0
P2	3/4"	1

**Variables flanges connections**  
4 bolts SAE flange (J518c)  
0 = UNC thread  
M = metric thread

**Control accessories**  
0 = Maxi flow  
9 = 90% maxi flow  
8 = 80% maxi flow  
7 = 70% maxi flow  
6 = 60% maxi flow  
5 = 50% maxi flow

**Control**  
C = Compensator  
F = RC pilot operated compensator  
L = RC pilot operated compensator "load sensing"

**Connection (drain + vent.)**  
0 = ext. drain + UNF thread  
2 = ext. drain + BSPP thread  
3 = int. drain + UNF thread  
4 = int. drain + BSPP thread

\* = 0 = Indust. uni-rotational / B = Indust. bi-rotational / M = Mobile bi-rotational

**OPERATING CHARACTERISTICS - TYPICAL [24 cSt]**

Pressure port	Series	Volumetric Displacement Vi	Flow Q [l/min], n = 1500 RPM				Input power P [kW], n = 1500 RPM				
			p = 0 bar	p = 140 bar		p = 300 bar		p = 7 bar	p = 140 bar	p = 300 bar	
P2 T6H29B	B02	5,8 ml/rev	8,7	7,0		5,1		0,5	2,6	5,1	
	B03	9,8 ml/rev	14,7	13,0		11,1		0,6	4,0	8,1	
	B04	12,8 ml/rev	19,2	17,5		15,6		0,6	5,0	10,4	
	B05	15,9 ml/rev	23,9	22,2		20,2		0,7	6,1	12,7	
	B06	19,8 ml/rev	29,7	28,0		26,1		0,7	7,5	15,6	
	B07	22,5 ml/rev	33,7	32,0		30,2		0,8	8,5	17,6	
	B08	24,9 ml/rev	37,4	35,7		33,7		0,8	9,3	19,5	
	B10	31,8 ml/rev	47,7	46,0		44,1		0,9	11,7	24,6	
P2 T6H29C	B12	41,0 ml/rev	61,5	59,8		57,9		1,2	14,9	31,5	
	B15	50,0 ml/rev	75,0	73,3		71,6 <sup>1)</sup>		1,3	18,1	35,7 <sup>1)</sup>	
			p = 0 bar	p = 140 bar		p = 240 bar		p = 7 bar	p = 140 bar	p = 240 bar	
				Indust.	Mobile	Indust.	Mobile				
		*03	10,8 ml/rev	16,2	11,2	10,7	7,7	-	1,3	5,3	-
		*05	17,2 ml/rev	25,8	20,8	20,3	17,3	15,8	1,4	7,5	12,2
		*06	21,3 ml/rev	31,9	26,9	26,4	23,4	21,9	1,5	8,9	14,7
		*08	26,4 ml/rev	39,6	34,6	34,1	31,1	29,6	1,6	10,7	17,7
		*10	34,1 ml/rev	51,1	46,1	45,6	42,6	41,1	1,7	13,4	22,3
		*12	37,1 ml/rev	55,6	50,6	50,1	47,1	45,6	1,7	14,4	24,1
		*14	46,0 ml/rev	69,0	64,0	63,5	60,5	59,0	1,9	17,6	29,5
	*17	58,3 ml/rev	87,4	82,4	81,9	78,9	77,4	2,1	21,9	36,9	
	*20	63,8 ml/rev	95,7	90,7	90,2	87,2	85,7	2,2	23,8	40,2	
	*22	70,3 ml/rev	105,4	100,4	99,9	96,9	95,4	2,3	26,1	44,1	
	*25	79,3 ml/rev	118,9	113,9	113,4	110,4	108,9	2,5	29,2	49,5	
	*28	88,8 ml/rev	133,2	128,2	127,7	125,8 <sup>2)</sup>	124,5 <sup>2)</sup>	2,8	32,7	48,5 <sup>2)</sup>	
	*31	100,0 ml/rev	150,0	145,0	144,5	142,6 <sup>2)</sup>	141,3 <sup>2)</sup>	2,8	36,5	54,4 <sup>2)</sup>	

<sup>1)</sup> B15 = 280 bar max. int.      <sup>2)</sup> 028 - 031 = 210 bar max. int.  
- Not to use because internal leakage greater than 50% theoretical flow.



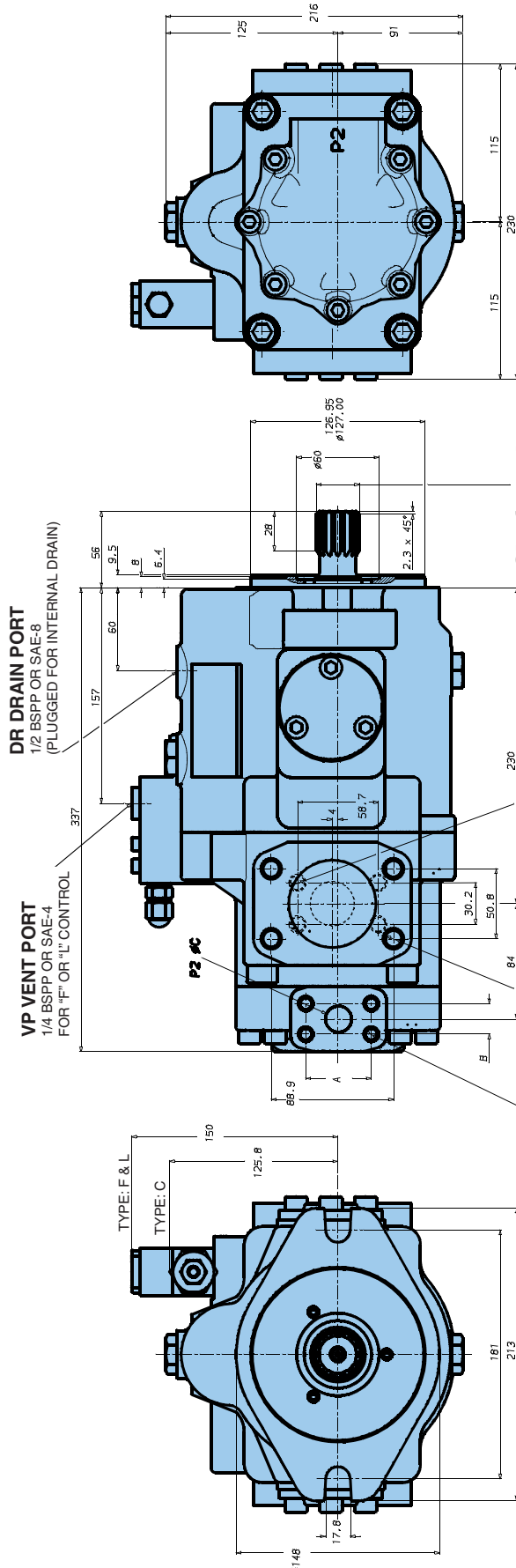

**Shaft code 3**

INVOLUTE SPLINE SAE C  
FLAT ROOT - SIDE FIT  
-498b-CLASS, 1-PITCH, 12/24  
14 TEETH - 30° PRESS. ANGLE

(M12 x 22 DEEP-METRIC VERSION)  
1/2"-13 UNC x 22 DEEP - 4 HOLES  
7/16"-14 UNC x 24 DEEP-4 HOLES

P1 Ø 31,8 for CCW ROT  
S Ø 63,5 for CW ROT

(M12 x 22 DEEP-METRIC VERSION)  
1/2"-13 UNC x 22 DEEP - 4 HOLES  
7/16"-14 UNC x 24 DEEP-4 HOLES

MOUNTING TORQUE 80 Nm

SIDE OF CONTROLS FOR CCW ROTATION

MOUNTING TORQUE 180 Nm

SIDE OF CONTROLS FOR CW ROTATION

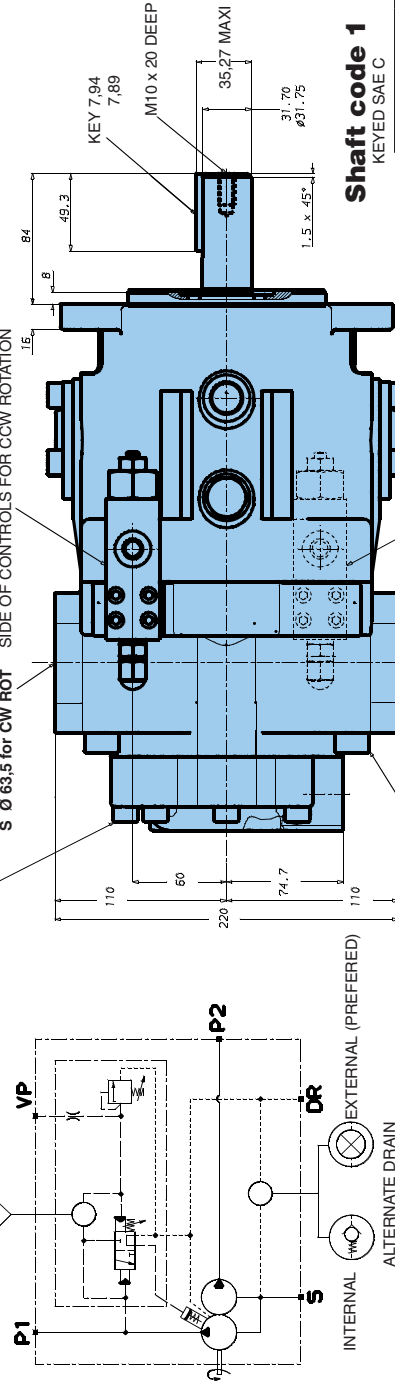

**Shaft code 1**

KEYED SAE C

Variable port		
Port	Code	Variable port
P2	0	52,4
P2	1	47,7
		26,2
		22,4
		19,0
		Ø C

MOUNTING TORQUE 41 Nm

MOUNTING TORQUE 180 Nm

P1 Ø 31,8 for CW ROT  
S Ø 63,5 for CCW ROT

MOUNTING TORQUE 180 Nm

MOUNTING TORQUE 41 Nm

SIDE OF CONTROLS FOR CW ROTATION

SIDE OF CONTROLS FOR CW ROTATION

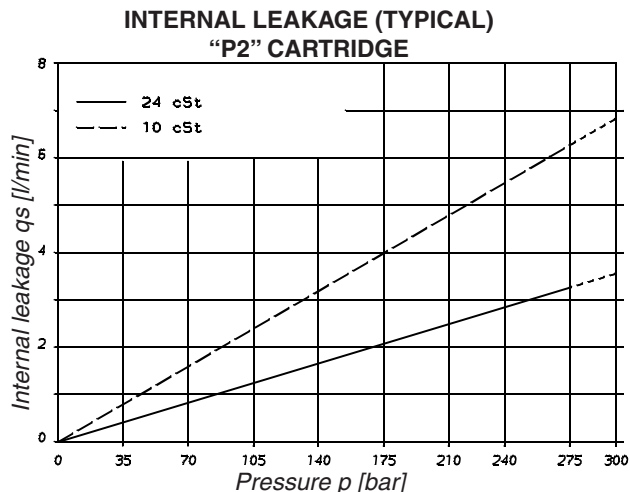

Do not operate pump more than 5 seconds at any speed or viscosity if internal leakage is higher than 50% of theoretical flow.

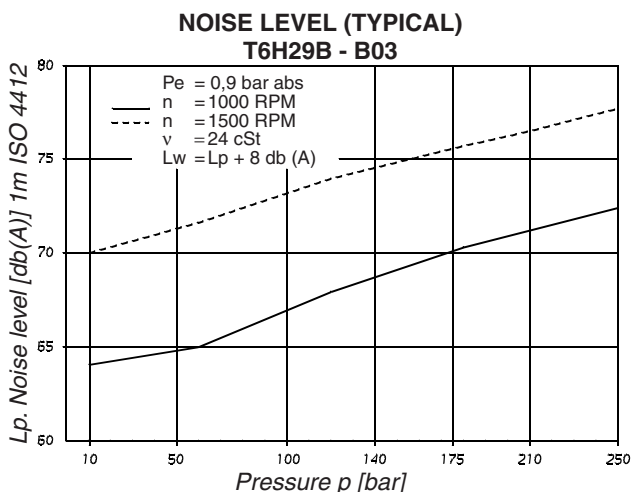

Noise level is given with each cartridge discharging at the pressure noted on the curve (P1 full flow).

**HYDROMECHANICAL POWER LOSS (TYPICAL)  
"P2" CARTRIDGE**

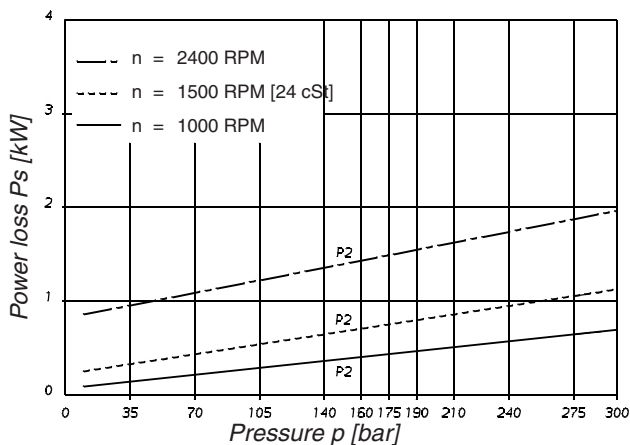

**OUTLET FLOW  
"P1" CARTRIDGE**

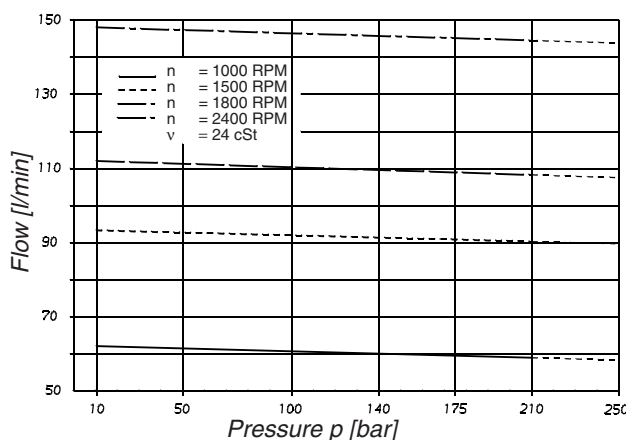

**OVERALL EFFICIENCY - "P1" CARTRIDGE  
Full displacement**

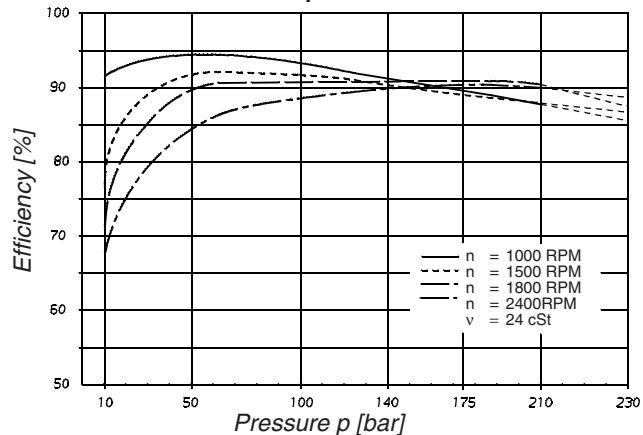

**INPUT HORSEPOWER - "P1" CARTRIDGE  
Full displacement**

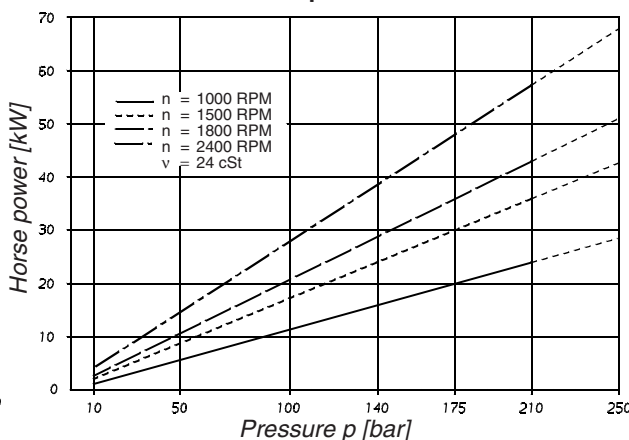

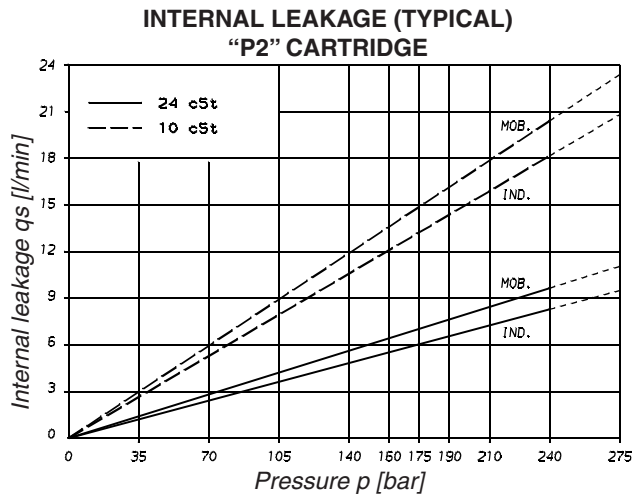

Do not operate pump more than 5 seconds at any speed or viscosity if internal leakage is higher than 50% of theoretical flow.

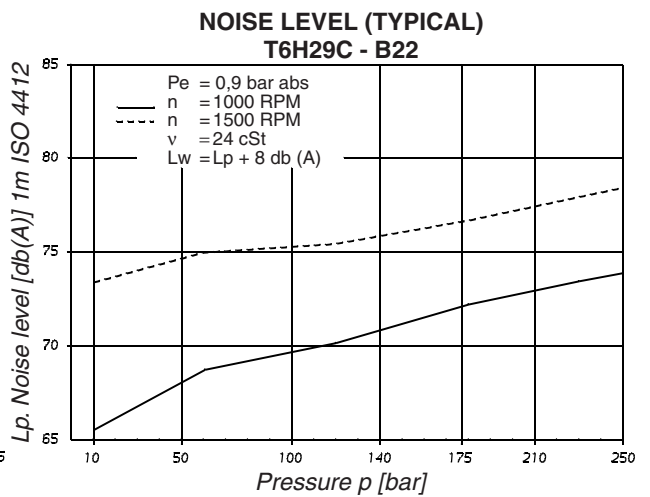

Noise level is given with each cartridge discharging at the pressure noted on the curve (P1 full flow).

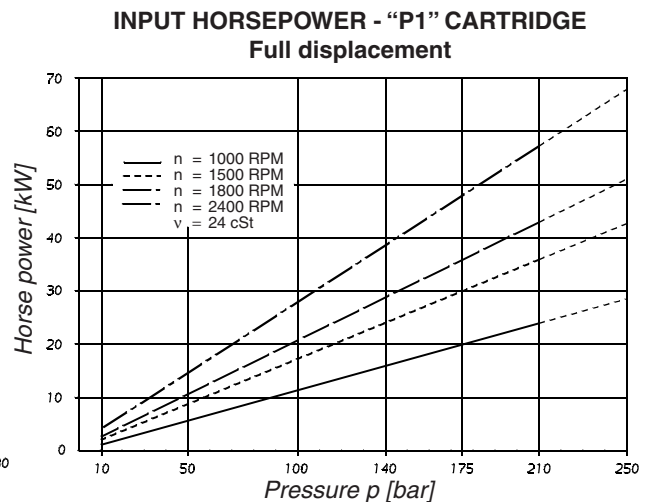
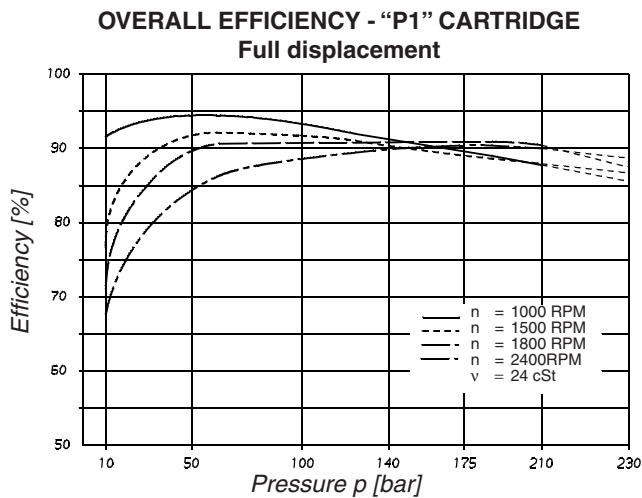
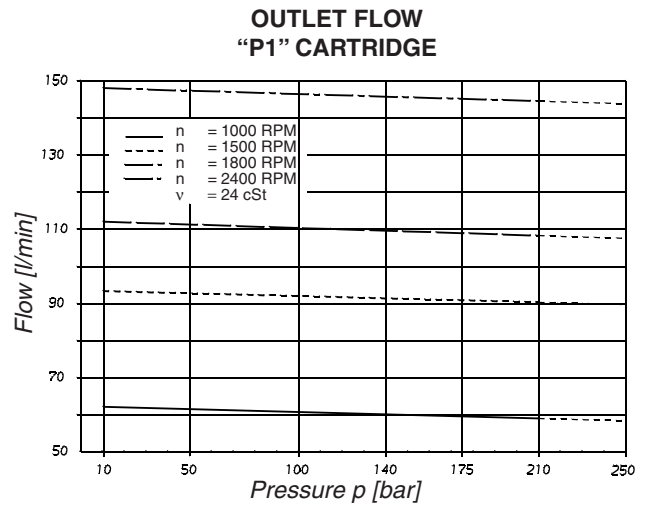
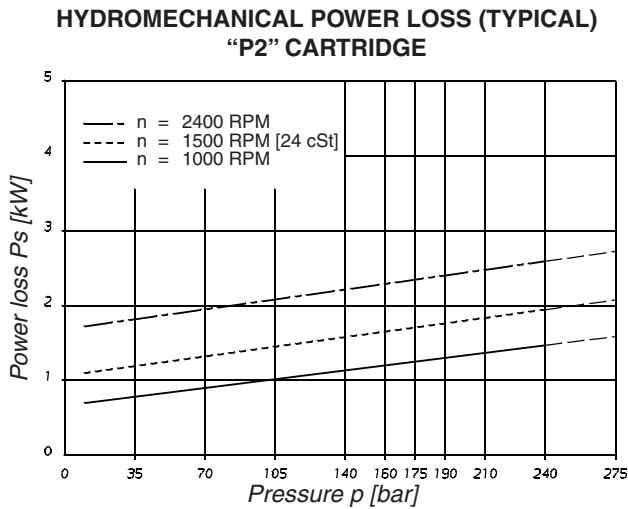

**Model No.** T6H29D - 042 - 1 L 1 B - 2 F 0 M 0 - 00 - ....

**Series and capacity P1  
(rotating group)**

61,9 ml/rev.

**Cam ring P2**

(Delivery at 0 bar & 1500 r.p.m.)

014 = 71,4 l/min

017 = 87,3 l/min

020 = 99,0 l/min

024 = 119,3 l/min

028 = 134,5 l/min

031 = 147,4 l/min

035 = 166,5 l/min

038 = 180,4 l/min

042 = 204,0 l/min

045 = 218,5 l/min

050 = 237,0 l/min

**Type of shaft**

1 = keyed (SAE C)

4 = splined (SAE C)

**Direct. of rotation (view on shaft end)**

R = clockwise

L = counter-clockwise

**Seal class**

1 = S1 BUNA N

5 = S5 VITON®

**Design letter**

**Modification**

**Porting combination**

Depend on the rotation - See page 26

**Variables port**

	Dia	Code
P2	1"1/4	0

**Variables flanges connections**

4 bolts SAE flange (J518c)

0 = UNC thread

M = metric thread)

**Control accessories**

0 = Maxi flow

9 = 90% maxi flow

8 = 80% maxi flow

7 = 70% maxi flow

6 = 60% maxi flow

5 = 50% maxi flow

**Control**

C = Compensator

F = RC pilot operated compensator

L = RC pilot operated compensator

"load sensing"

**Connection (drain + vent.)**

0 = ext. drain + UNF thread

2 = ext. drain + BSPP thread

3 = int. drain + UNF thread

4 = int. drain + BSPP thread

**OPERATING CHARACTERISTICS - TYPICAL [24 cSt]**

Pressure port	Series	Volumetric Displacement Vi	Flow Q [l/min], n = 1500 RPM			Input power P [kW], n = 1500 RPM		
			p = 0 bar	p = 140 bar	p = 240 bar	p = 7 bar	p = 140 bar	p = 240 bar
P2 T6H29D	014	47,6 ml/rev	71,4	62,1	55,9	2,3	18,5	30,6
	017	58,2 ml/rev	87,3	78,0	71,8	2,5	22,2	37,0
	020	66,0 ml/rev	99,0	89,7	83,5	2,8	24,9	41,7
	024	79,5 ml/rev	119,3	110,0	103,8	3,0	29,6	49,8
	028	89,7 ml/rev	134,5	125,2	119,0	3,2	33,2	55,9
	031	98,3 ml/rev	147,4	138,1	131,9	3,3	36,2	61,0
	035	111,0 ml/rev	166,5	157,2	151,0	3,5	40,7	68,7
	038	120,3 ml/rev	180,4	171,1	164,9	3,7	43,9	74,3
	042 <sup>1)</sup>	136,0 ml/rev	204,0	194,7	188,5	4,0	49,4	83,7
	045 <sup>1)</sup>	145,7 ml/rev	218,5	209,2	203,0	4,1	52,8	89,5
050 <sup>1)</sup>	158,0 ml/rev	237,0	227,7	224,0 <sup>2)</sup>	4,4	57,0	85,0 <sup>2)</sup>	

<sup>1)</sup> 042 - 045 - 050 = max. 2200 RPM <sup>2)</sup> 050 = 210 bar max. int.

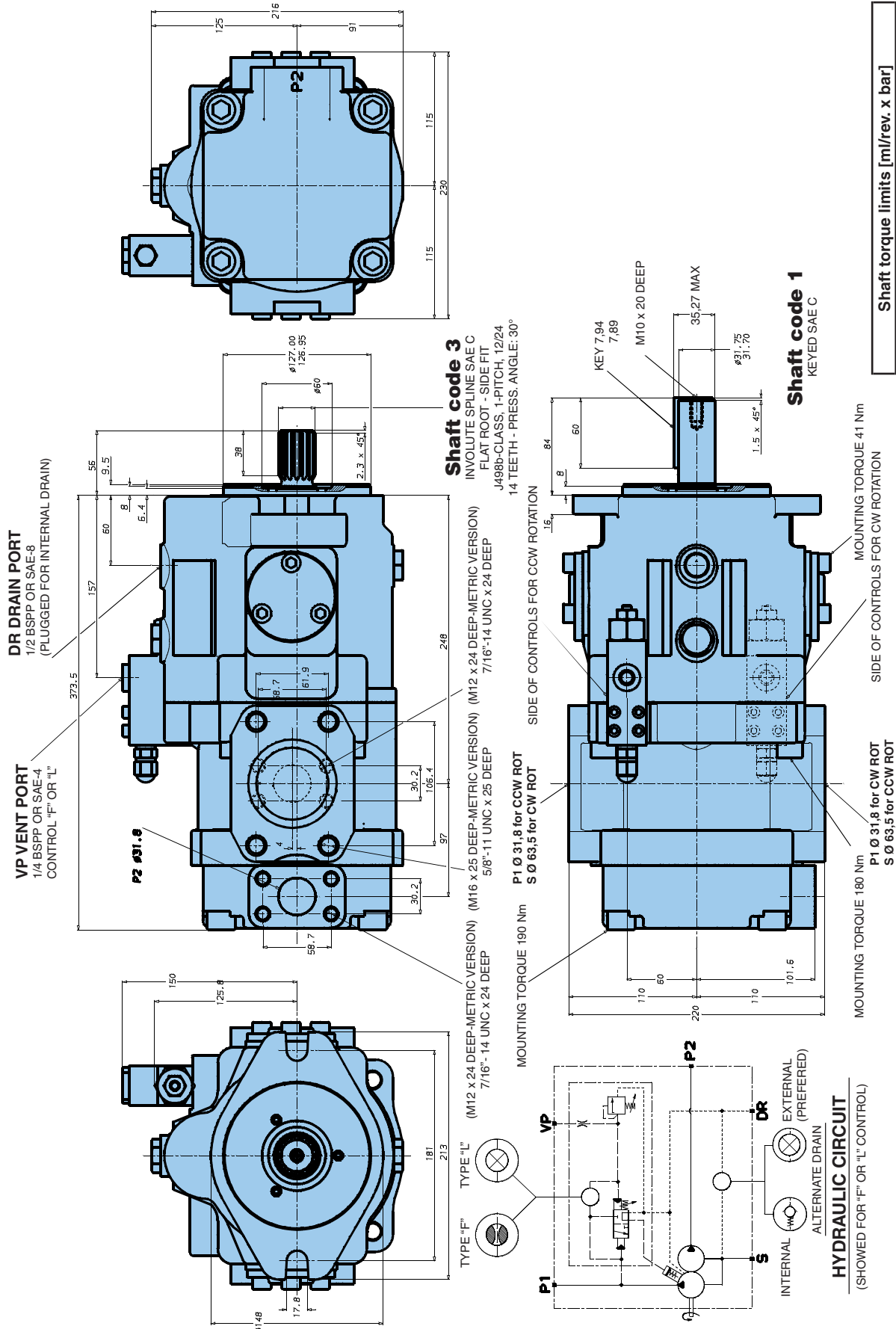

<b>Shaft torque limits [ml/rev. x bar]</b>	
Shaft	Vi x p max.
1	43240

**INTERNAL LEAKAGE (TYPICAL)  
"P2" CARTRIDGE**

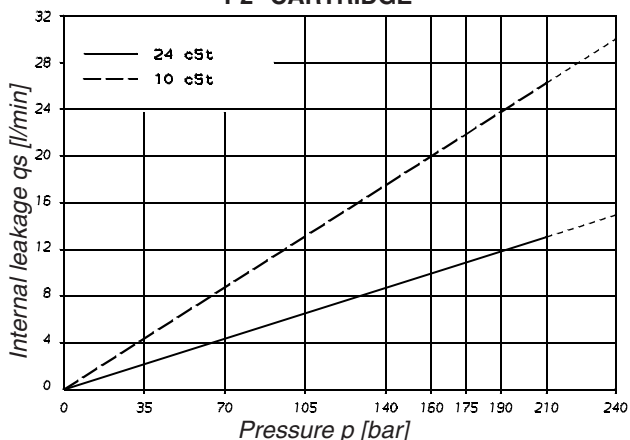

Do not operate pump more than 5 seconds at any speed or viscosity if internal leakage is higher than 50% of theoretical flow.

**NOISE LEVEL (TYPICAL)  
T6H29D - 038**

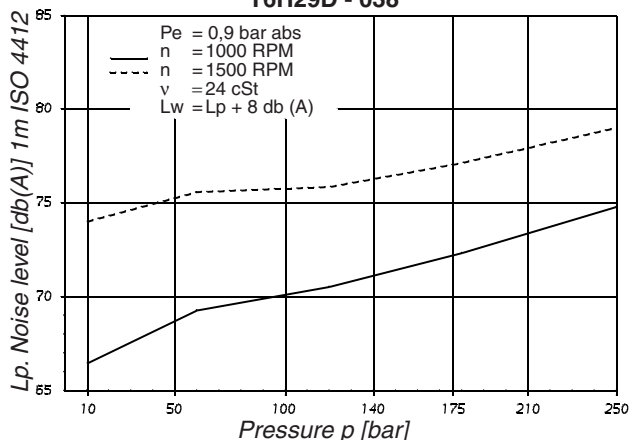

Noise level is given with each cartridge discharging at the pressure noted on the curve (P1 full flow).

**HYDROMECHANICAL POWER LOSS (TYPICAL)  
"P2" CARTRIDGE**

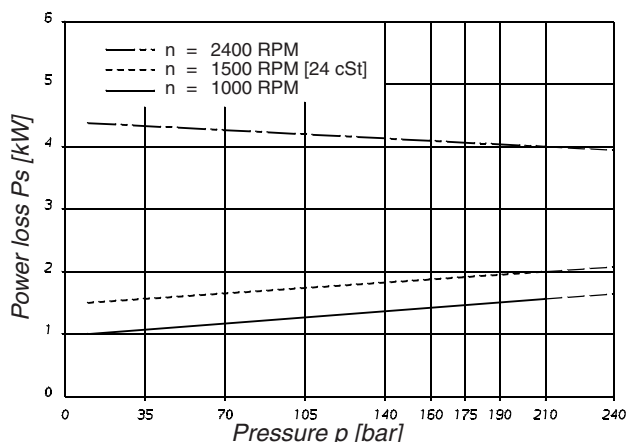

**OUTLET FLOW  
"P1" CARTRIDGE**

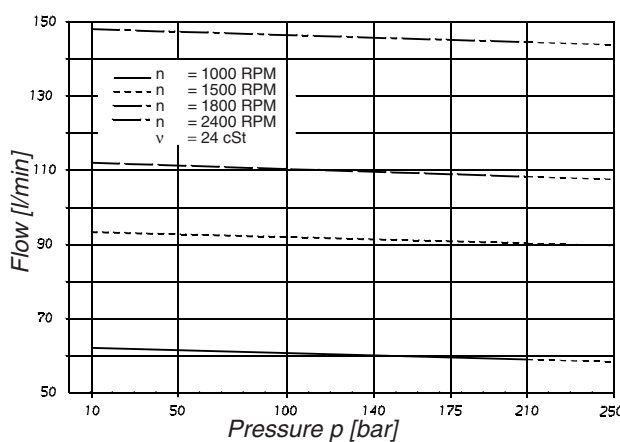

**OVERALL EFFICIENCY - "P1" CARTRIDGE  
Full displacement**

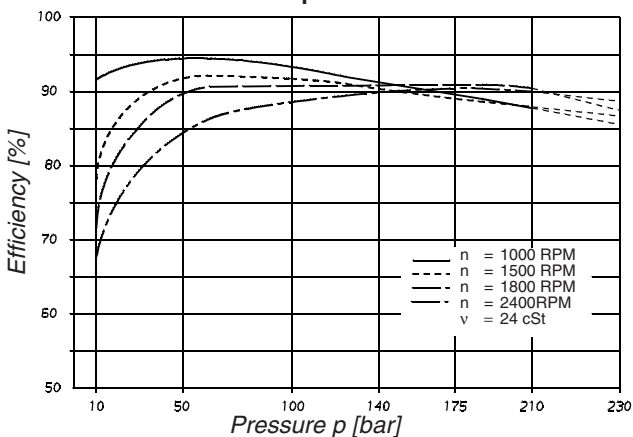

**INPUT HORSEPOWER - "P1" CARTRIDGE  
Full displacement**

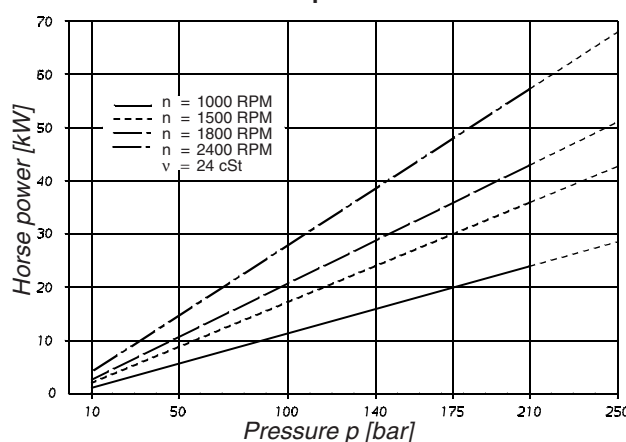



Model No. T6H29DB - 042 B10 - 1 L 1 B - 2 F 0 M 0 - 00 - ....

**Series and capacity P1 (rotating group)**  
61,9 ml/rev.

**Cam ring P2**  
(Delivery at 0 bar & 1500 r.p.m.)  
014 = 71,4 l/min  
017 = 87,3 l/min  
020 = 99,0 l/min  
024 = 119,3 l/min  
028 = 134,5 l/min  
031 = 147,4 l/min  
035 = 166,5 l/min  
038 = 180,4 l/min  
042 = 204,0 l/min  
045 = 218,5 l/min  
050 = 237,0 l/min

**Cam ring P3**  
(Delivery at 0 bar & 1500 r.p.m.)  
B02 = 8,7 l/min  
B03 = 14,7 l/min  
B04 = 19,2 l/min  
B05 = 23,9 l/min  
B06 = 29,7 l/min  
B07 = 33,7 l/min  
B08 = 37,4 l/min  
B10 = 47,7 l/min  
B12 = 61,5 l/min  
B15 = 75,0 l/min

**Type of shaft**  
1 = keyed (SAE C)  
3 = splined (SAE C)

**Direct. of rotation (view on shaft end)**  
R = clockwise  
L = counter-clockwise

**Seal class**  
1 = S1 BUNA N  
5 = S5 VITON®

**Modification**

**Porting combination**  
Depend on the rotation - See page 27

**Variable port**

	Dia	Code
P2	1"	0
P3	3/4"	1

**Variables flanges connections**

4 bolts SAE flange (J518c)  
0 = UNC thread  
M = metric thread)

**Control accessories**

0 = Maxi flow  
9 = 90% maxi flow  
8 = 80% maxi flow  
7 = 70% maxi flow  
6 = 60% maxi flow  
5 = 50% maxi flow

**Control**

C = Compensator  
F = RC pilot operated compensator  
L = RC pilot operated compensator "load sensing"

**Connection (drain + vent.)**

0 = ext. drain + UNF thread  
2 = ext. drain + BSPP thread  
3 = int. drain + UNF thread  
4 = int. drain + BSPP thread

**Design letter**

**OPERATING CHARACTERISTICS - TYPICAL [24 cSt]**

Pressure port	Series	Volumetric Displacement Vi	Flow Q [l/min], n = 1500 RPM			Input power P [kW], n = 1500 RPM		
			p = 0 bar	p = 140 bar	p = 240 bar	p = 7 bar	p = 140 bar	p = 240 bar
P2	014	47,6 ml/rev	71,4	62,1	55,9	2,3	18,5	30,6
	017	58,2 ml/rev	87,3	78,0	71,8	2,5	22,2	37,0
	020	66,0 ml/rev	99,0	89,7	83,5	2,8	24,9	41,7
	024	79,5 ml/rev	119,3	110,0	103,8	3,0	29,6	49,8
	028	89,7 ml/rev	134,5	125,2	119,0	3,2	33,2	55,9
	031	98,3 ml/rev	147,4	138,1	131,9	3,3	36,2	61,0
	035	111,0 ml/rev	166,5	157,2	151,0	3,5	40,7	68,7
	038	120,3 ml/rev	180,4	171,1	164,9	3,7	43,9	74,3
	042 <sup>1)</sup>	136,0 ml/rev	204,0	194,7	188,5	4,0	49,4	83,7
	045 <sup>1)</sup>	145,7 ml/rev	218,5	209,2	203,0	4,1	52,8	89,5
050 <sup>1)</sup>	158,0 ml/rev	237,0	227,7	224,0 <sup>2)</sup>	4,4	57,0	85,0 <sup>2)</sup>	
			p = 0 bar	p = 140 bar	p = 300 bar	p = 7 bar	p = 140 bar	p = 300 bar
P3	B02	5,8 ml/rev	8,7	7,0	5,1	0,5	2,6	5,1
	B03	17,2 ml/rev	14,7	13,0	11,1	0,6	4,0	8,1
	B04	21,3 ml/rev	19,2	17,5	15,6	0,6	5,0	10,4
	B05	26,4 ml/rev	23,9	22,2	20,2	0,7	6,1	12,7
	B06	34,1 ml/rev	29,7	28,0	26,1	0,7	7,5	15,6
	B07	37,1 ml/rev	33,7	32,0	30,2	0,8	8,5	17,6
	B08	46,0 ml/rev	37,4	35,7	33,7	0,8	9,3	19,5
	B10	58,3 ml/rev	47,7	46,0	44,1	0,9	11,7	24,6
	B12	63,8 ml/rev	61,5	59,8	57,9	1,2	14,9	31,5
	B15	70,3 ml/rev	75,0	73,3	71,6 <sup>3)</sup>	1,3	18,1	35,7 <sup>3)</sup>

<sup>1)</sup> 042 - 045 - 050 = max. 2200 RPM

<sup>2)</sup> 050 = 210 bar max. int.

<sup>3)</sup> B15 = 280 bar max. int.

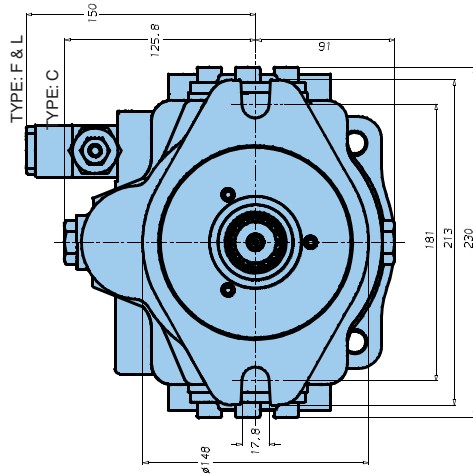
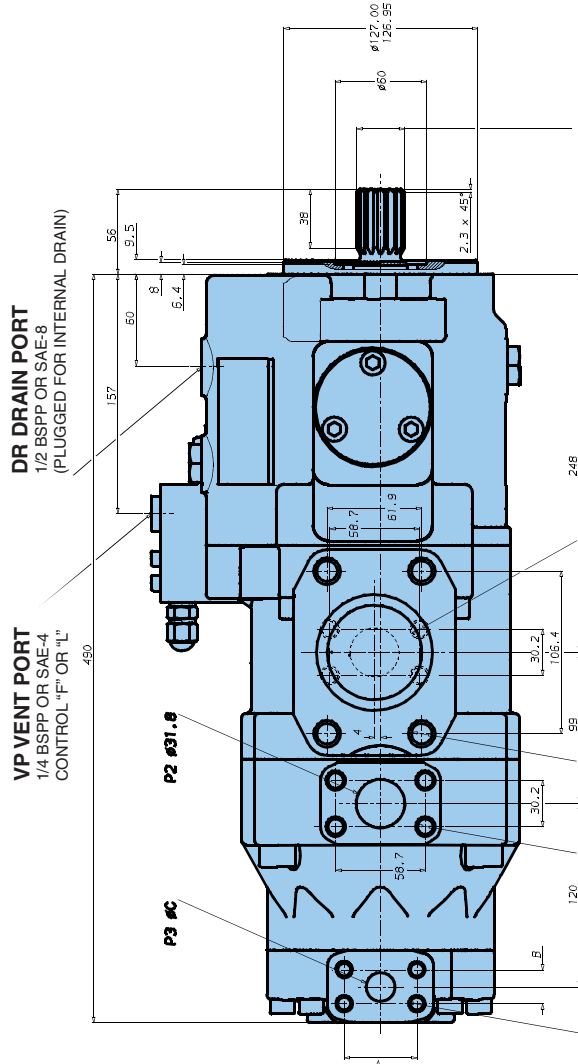

**Shaft code 3**

INVOLUTE SPLINE SAE C  
FLAT ROOT - SIDE FIT  
J498b-CLASS, 1-PITCH, 12/24  
14 TEETH - PRESS. ANGLE: 30°

(M12 x 24 DEEP-METRIC VERSION)  
7/16"-14 UNC x 24 DEEP

(M16 x 25 DEEP-METRIC VERSION)  
5/8"-11 UNC x 25 DEEP

(M10 x 19 DEEP-METRIC VERSION)  
3/8"-16 UNC x 19 DEEP

(M12 x 24 DEEP-METRIC VERSION)  
7/16"-14 UNC x 24 DEEP

**P1 Ø 31.8 for CCW ROT  
S Ø 76 for CW ROT**

**MOUNTING TORQUE 190 Nm**

**MOUNTING TORQUE 80 Nm**

**MOUNTING TORQUE 160 Nm**

**TYPE "L"**

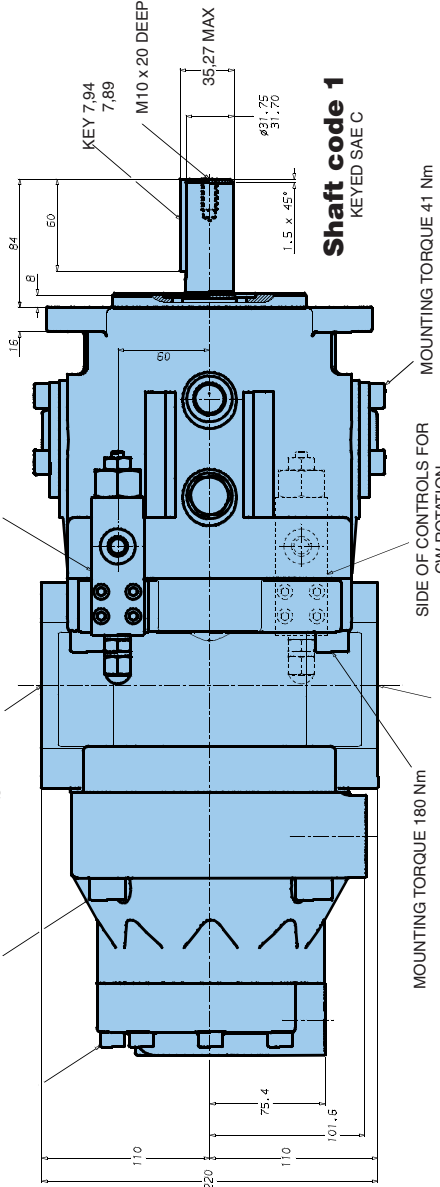

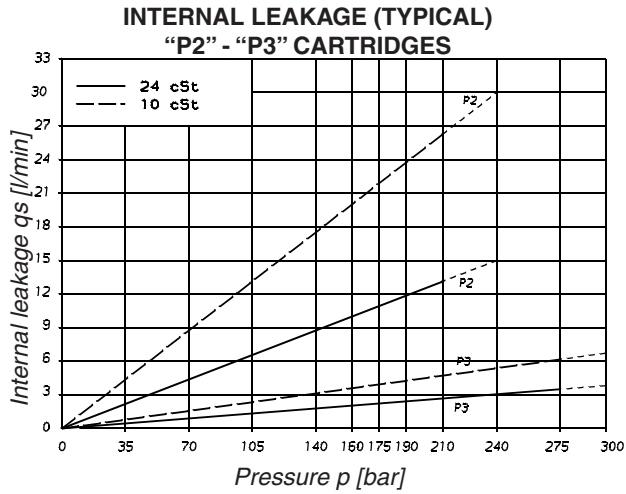

Do not operate pump more than 5 seconds at any speed or viscosity if internal leakage is higher than 50% of theoretical flow.

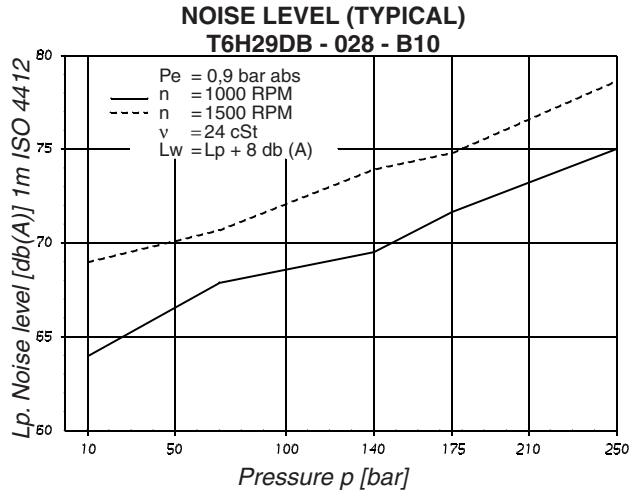

Noise level is given with each cartridge discharging at the pressure noted on the curve (P1 full flow).

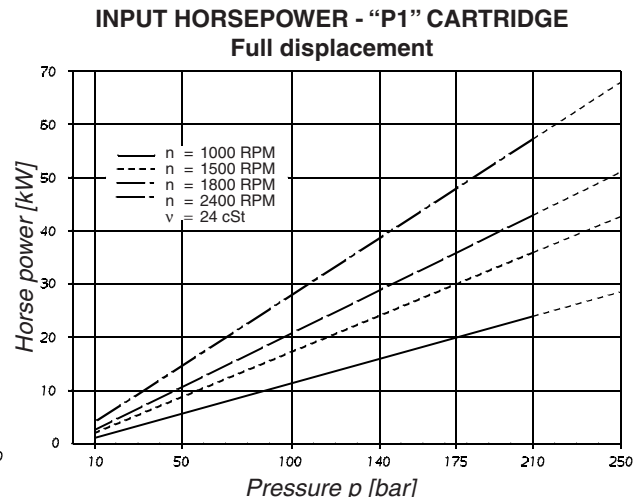
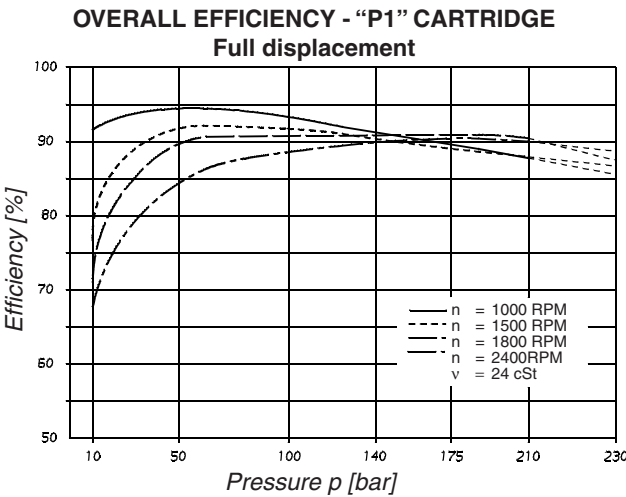
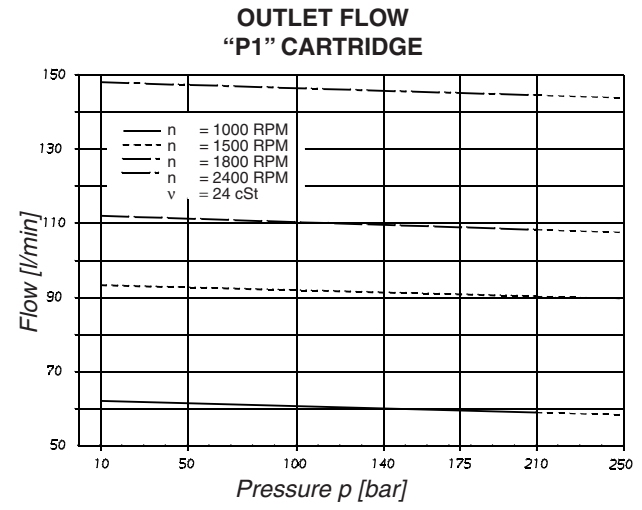
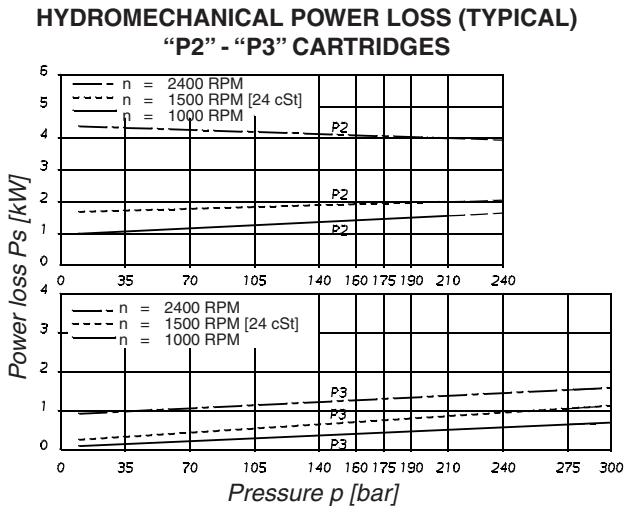

# DEPEND ON THE ROTATION

**T6H20B - T6H20C  
 T6H29B - T6H29C**

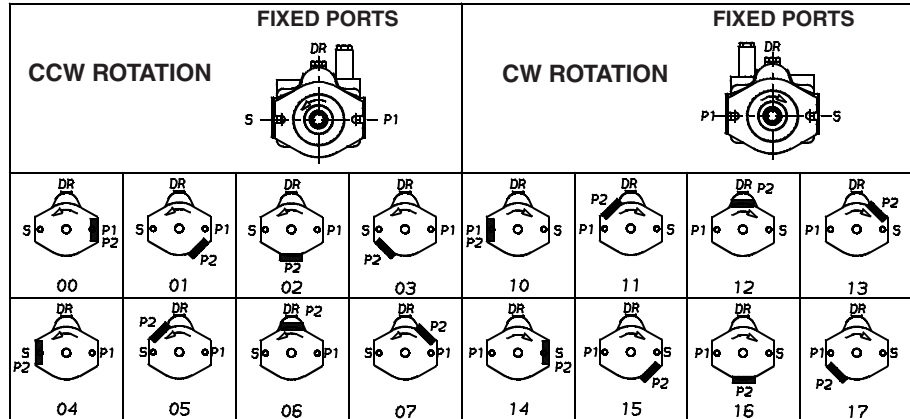

**T6H29D**

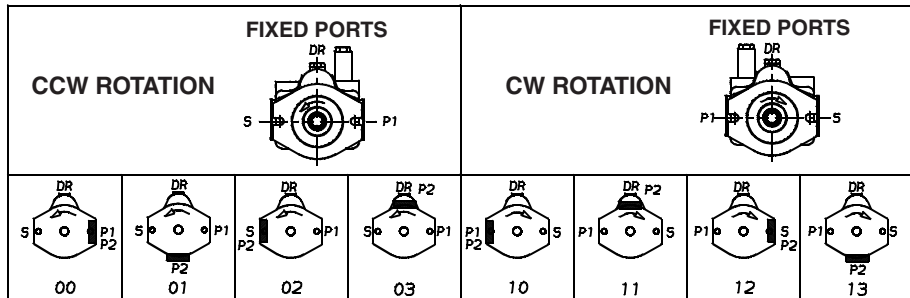

# DEPEND ON THE ROTATION

T6H29DB

FIXED PORTS				FIXED PORTS			
CCW ROTATION				CW ROTATION			
00	08	15	24	40	48	56	64
01	09	17	25	41	49	57	65
02	10	18	26	42	50	58	66
03	11	19	27	43	51	59	67
04	12	20	28	44	52	60	68
05	13	21	29	45	53	61	69
06	14	22	30	46	54	62	70
07	15	23	31	47	55	63	71

# Parker Worldwide

**AE – UAE, Dubai**  
Tel: +971 4 8127100  
parker.me@parker.com

**AR – Argentina, Buenos Aires**  
Tel: +54 3327 44 4129

**AT – Austria, Wiener Neustadt**  
Tel: +43 (0)2622 23501-0  
parker.austria@parker.com

**AT – Eastern Europe, Wiener Neustadt**  
Tel: +43 (0)2622 23501 900  
parker.easteurope@parker.com

**AU – Australia, Castle Hill**  
Tel: +61 (0)2-9634 7777

**AZ – Azerbaijan, Baku**  
Tel: +994 50 2233 458  
parker.azerbaijan@parker.com

**BE/LU – Belgium, Nivelles**  
Tel: +32 (0)67 280 900  
parker.belgium@parker.com

**BR – Brazil, Cachoeirinha RS**  
Tel: +55 51 3470 9144

**BY – Belarus, Minsk**  
Tel: +375 17 209 9399  
parker.belarus@parker.com

**CA – Canada, Milton, Ontario**  
Tel: +1 905 693 3000

**CH – Switzerland, Etoy**  
Tel: +41 (0) 21 821 02 30  
parker.switzerland@parker.com

**CL – Chile, Santiago**  
Tel: +56 2 623 1216

**CN – China, Shanghai**  
Tel: +86 21 2899 5000

**CZ – Czech Republic, Klecany**  
Tel: +420 284 083 111  
parker.czechrepublic@parker.com

**DE – Germany, Kaarst**  
Tel: +49 (0)2131 4016 0  
parker.germany@parker.com

**DK – Denmark, Ballerup**  
Tel: +45 43 56 04 00  
parker.denmark@parker.com

**ES – Spain, Madrid**  
Tel: +34 902 330 001  
parker.spain@parker.com

**FI – Finland, Vantaa**  
Tel: +358 (0)20 753 2500  
parker.finland@parker.com

**FR – France, Contamine s/Arve**  
Tel: +33 (0)4 50 25 80 25  
parker.france@parker.com

**GR – Greece, Athens**  
Tel: +30 210 933 6450  
parker.greece@parker.com

**HK – Hong Kong**  
Tel: +852 2428 8008

**HU – Hungary, Budapest**  
Tel: +36 1 220 4155  
parker.hungary@parker.com

**IE – Ireland, Dublin**  
Tel: +353 (0)1 466 6370  
parker.ireland@parker.com

**IN – India, Mumbai**  
Tel: +91 22 6513 7081-85

**IT – Italy, Corsico (MI)**  
Tel: +39 02 45 19 21  
parker.italy@parker.com

**JP – Japan, Fujisawa**  
Tel: +(81) 4 6635 3050

**KR – South Korea, Seoul**  
Tel: +82 2 559 0400

**KZ – Kazakhstan, Almaty**  
Tel: +7 7272 505 800  
parker.easteurope@parker.com

**LV – Latvia, Riga**  
Tel: +371 6 745 2601  
parker.latvia@parker.com

**MX – Mexico, Apodaca**  
Tel: +52 81 8156 6000

**MY – Malaysia, Shah Alam**  
Tel: +60 3 7849 0800

**NL – The Netherlands, Oldenzaal**  
Tel: +31 (0)541 585 000  
parker.nl@parker.com

**NO – Norway, Ski**  
Tel: +47 64 91 10 00  
parker.norway@parker.com

**NZ – New Zealand, Mt Wellington**  
Tel: +64 9 574 1744

**PL – Poland, Warsaw**  
Tel: +48 (0)22 573 24 00  
parker.poland@parker.com

**PT – Portugal, Leca da Palmeira**  
Tel: +351 22 999 7360  
parker.portugal@parker.com

**RO – Romania, Bucharest**  
Tel: +40 21 252 1382  
parker.romania@parker.com

**RU – Russia, Moscow**  
Tel: +7 495 645-2156  
parker.russia@parker.com

**SE – Sweden, Spånga**  
Tel: +46 (0)8 59 79 50 00  
parker.sweden@parker.com

**SG – Singapore**  
Tel: +65 6887 6300

**SK – Slovakia, Banská Bystrica**  
Tel: +421 484 162 252  
parker.slovakia@parker.com

**SL – Slovenia, Novo Mesto**  
Tel: +386 7 337 6650  
parker.slovenia@parker.com

**TH – Thailand, Bangkok**  
Tel: +662 717 8140

**TR – Turkey, Istanbul**  
Tel: +90 216 4997081  
parker.turkey@parker.com

**TW – Taiwan, Taipei**  
Tel: +886 2 2298 8987

**UA – Ukraine, Kiev**  
Tel: +380 44 494 2731  
parker.ukraine@parker.com

**UK – United Kingdom, Warwick**  
Tel: +44 (0)1926 317 878  
parker.uk@parker.com

**US – USA, Cleveland (industrial)**  
Tel: +1 216 896 3000

**US – USA, Lincolnshire (mobile)**  
Tel: +1 847 821 1500

**VE – Venezuela, Caracas**  
Tel: +58 212 238 5422

**ZA – South Africa, Kempton Park**  
Tel: +27 (0)11 961 0700  
parker.southafrica@parker.com

**European Product Information Centre**  
Free phone: 00 800 27 27 5374  
(from AT, BE, CH, CZ, DE, DK, EE, ES, FI, FR, IE, IL, IS, IT, LU, MT, NL, NO, PL, PT, RU, SE, UK, ZA)



**Parker Hannifin Ltd.**  
Tachbrook Park Drive  
Tachbrook Park, Warwick CV34 6TU  
United Kingdom  
Tel.: +44 (0) 1926 317 878  
Fax: +44 (0) 1926 317 855  
www.parker.com